

Dynaco PAS-4

Vacuum Tube Preamplifier

Owner's Manual

Dynaco
A Division of Panor Corporation

125 Cabot Court
Hauppauge, New York 11788

(516) 434-1200
(516) 434-1457 FAX

Bob01605@aol.com

Table on Contents

Introduction	2
Rear Panel Inputs and Outputs	3
Operation	4
Tube Substitution and Replacement	7
Minimizing Noise in the System	8
PAS-4 Specifications	9
Warranty	10
PC Board Parts List	11
Schematics	13

Bob01605@aol.com

- Please read this manual thoroughly before hookup to your system -

Introduction

Congratulations on your purchase of the Dynaco PAS-4 Preamp. This preamplifier was designed to provide the highest combination of quality and value available, which is the Dynaco tradition.

Only very high quality components have been used in manufacturing the PAS-4. Examples of this are the low noise metal-film resistors, polypropylene film capacitors, and selected (tested) vacuum tubes. Likewise, the high quality rotary switches and potentiometers provide better performance and reliability than what is found in most other audio equipment.

Unique to this modern PAS-4 vacuum tube design is its power supply buffering circuitry - found in no other preamp of this class. We have included a separate buffer circuit for *each* of the six tubes in the PAS-4, allowing each amplification stage to function more independently, (as if each one had its own separate power supply). This contributes significantly to the extraordinary sonic clarity of the PAS-4:

The PAS-4 contains a true state-of-the-art phono preamp section. It provides a front panel switched "external processing loop", for use with a graphic equalizer or other signal processing equipment. It also includes full provisions for tape dubbing between two tape decks ("1 to 2" and "2 to 1").

You will find the PAS-4 to *sound* better than the large majority of other preamplifiers - both solid state *and* vacuum tube designs - regardless of price. Its flexibility and full-featured styling is without parallel in affordable preamps. Your PAS-4 was designed and built entirely in the USA. We are proud to offer this outstanding preamplifier to discerning audiophiles the world over.

Dynaco Engineering Group

Bob01605@aol.com

Rear Panel Inputs and Outputs

Inputs - Phono:

These inputs will accommodate "moving magnet" or high output "moving coil" cartridges which have output levels of 1.0mV or higher.

In the lower right hand corner of the rear panel is the preamp's chassis ground terminal. This thumbscrew is provided for attaching the separate ground wire often provided on turntables. (see Minimizing System Noise on page 7)

Inputs - Tuner, CD, Video, Aux., Tape 1 & 2:

These inputs receive standard high level (line) input signals from other equipment. The Tape Inputs of the PAS-4 connect to Line Outputs (Play) on tape decks.

Tape Outputs:

Signals sent to these outputs are at line level. (Phono signals are first amplified and equalized). Tape Outputs are unaffected by external processing circuits, or by the PAS's Mono or Volume controls. The preamp's Tape Outputs connect to the tape deck(s) Line (Record) Inputs .

Preamplifier Main Outputs:

Two pairs of outputs are provided for your power amplifier(s). The RCA jacks in the left channel pair are connected together inside of the PAS-4, as is the right channel pair.

EQ (External Processing Loop):

"EQ Out" are line level outputs which can be connected to the inputs of an external signal processor such as an equalizer, time delay, or noise reduction unit. "EQ In" are for line level inputs coming from the signal processor outputs.

Bob01605@aol.com

Operation

Turn-On Delay and Visual Indicator

When you turn on the PAS-4, the lamp above the PWR (power) switch glows RED and a timer circuit is evoked which keeps the preamp outputs at zero volts during the warm-up period. This 45-second warm-up period allows the tube filaments to fully heat, the high-voltage section of the power supply to reach full potential, and for the preamp output circuitry to settle, (avoiding loud turn-on "thumps"). When warm-up is finished, the lamp turns to GREEN and the preamp outputs are operative.

When you turn off the PAS-4, the outputs immediately clamp to zero volts. Turning the preamp back on at this point will require again waiting through the warm-up period.

Input Selection:

Your choice of a signal source is indicated by the INPUT switch position you select. This signal source is what you will hear. It is also sent to the Tape (recording) Outputs and the EQ Outputs, (as long as the TAPE MONITOR and TAPE DUBBING switches are set to their "SOURCE" positions).

Tape Deck Selection - Listening:

You may bypass the INPUT switch selection by using the TAPE MONITOR switch, in which case the signal from the selected tape deck is what you will hear and what is sent to the EQ Out jacks.

When the TAPE MONITOR switch is turned to Tape 1 or Tape 2, what you hear is the signal from the tape deck playback head, not the original source signal (which is being recorded onto tape via the tape deck record head). This feature allows direct comparison of the signal source with taped replica without affecting the recording process. (If a tape deck does not have separate record and playback heads, then the signal you hear when using the TAPE MONITOR switch is the same signal being sent to the tape deck to be recorded.)

Bob01605@aol.com

Operation - cont.

Tape Deck Selection - Recording:

The TAPE DUBBING switch determines which signals are sent to the tape decks for recording purposes. If the TAPE DUBBING switch is set to "SOURCE", both tape decks receive the same signal - the one indicated by the position of the INPUT switch.

A copy of a tape can be made when the TAPE DUBBING switch is set to either "2 to 1" or "1 to 2". (When this is done, the signal selected by the INPUT switch is disconnected from both tape decks.)

When the TAPE DUBBING switch is set to "2 to 1", the output of tape deck #2 goes to the input of tape deck #1 to be recorded. When the TAPE DUBBING switch is set to "1 to 2", the output of tape deck #1 goes to the input of tape deck #2 to be recorded.

The TAPE MONITOR switch can be used to listen to the "source" tape deck (the original recording) or the "target" tape deck (the dubbed recording) while tape dubbing is being done. However, if the TAPE MONITOR switch is set to "SOURCE", one can listen to any music signal selected with the INPUT switch *while tape dubbing is in progress*.

Note: Some older tape decks which do not have high impedance input circuitry can present non-linear loads to a preamp's Tape Outputs even when the tape decks are turned off. This can be a problem because the Tape Outputs are usually connected to which ever signal source has been selected by the INPUT switch. The "always present" non-linear load can degrade performance on most preamps.

With the PAS-4 there is a solution to the use of lower input impedance tape decks. Simply keep the TAPE DUBBING switch positioned to "1 to 2" or "2 to 1" when the deck is not in use. This disconnects the signal selected by the INPUT switch from both tape decks, as mentioned previously.

Bob01605@aol.com

Operation - cont.

<p>The following controls affect all signals which are heard through the speakers. They have no effect, however, on signals being recorded at the Tape Outputs.</p>

EQ Switch:

Pushing IN the EQ switch inserts a signal processing device into the preamplifier signal path (assuming such a device is connected to the EQ Inputs and Outputs). The part of the signal path containing such a device is called the External Processor Loop (EPL). Such devices include equalizers, time delays or ambiance simulators, expanders, compressors, and noise reduction systems. When the EQ switch is in the OUT position, any equipment plugged into the EQ inputs is effectively removed from the preamplifier signal path. Therefore an unpowered device connected to the EQ Inputs and Outputs will not deteriorate the PAS-4's performance (which can happen with some tape decks, as mentioned above).

Note that the EQ inputs can also be used as a second set of Auxiliary Inputs - (for a second tuner, second CD player, etc.) Therefore, the EQ switch itself can also function as an additional input selector.

Mono Switch:

When this button is IN, left and right channel information is combined and the composite signal is fed to both left and right outputs. In this mode the sound image should appear to be centrally located between the loudspeakers. This switch is useful when listening to monophonic program material. It cancels the unwanted vertical phonograph modulations which are heard as noise from monaural records.

Balance Control:

This adjusts the proportion of left and right channel signals going to the preamp's Line Level amplification stage (and therefore to the preamp's main outputs). Only the Left signal will be heard with the control fully counterclockwise, and only the Right signal at the other extreme. The function of the BALANCE control is to compensate for unbalanced Left and Right channel signal levels (from phonograph records, for instance) or to compensate for non-symmetrical room acoustics (from furniture, wall reflections, etc.).

Bob01605@aol.com

Tube Substitution and Replacement

CAUTION: Before taking the top cover off of the PAS-4 to check or replace tubes, ensure that the unit is unplugged from its AC (wall) outlet and that a 3-minute "power-supply-discharge period" has been allowed. (Never touch live circuit elements in vacuum tube equipment because high voltages are present when these units are turned on.) Gloves may be worn when changing tubes.

The tubes in your PAS-4 could provide 5,000 to 10,000 hours of use. We recommend that tubes be replaced after no more than 3,000 hours of use to avoid the slightly "muffled" sound or slight bass "roll-off" which can begin to occur with old tubes.

Microphonics (various "pinging" or "howling" sounds) is due to a tube being overly sensitive to physical vibrations. To avoid it, do not operate vacuum tube equipment on top of vibrating surfaces (such as loud-speakers). But if a tube is so sensitive that just having the preamp turned on causes the microphonic sounds, the tube will have to be replaced. It can happen that a tube becomes microphonic with age or that it is only microphonic before it warms up (or only after it warms up).

The most common type of problem in tube preamplifiers is excessive noise caused by a worn or faulty tube. The characteristics of this noise can vary a great deal. If a noise problem occurs with your PAS-4, 99% of the time it will be due to a faulty tube. When a novice vacuum tube preamplifier owner complains: "There is something wrong with my preamp!", it is usually that a tube simply needs to be replaced.

The most certain method for confirming a faulty tube is by substitution of a known good tube.

When removing a tube, grasp the tube socket with one hand and the tube with the other hand. Move the tube (slightly) from side to side while pulling outward.

The most likely source of tube noise in the PAS-4 is the phono section first stage tubes V1 (left channel) or V4 (right channel). Less likely, but to be suspected next, would be the phono stage second stage tubes V2 (left) or V5 (right). The line stage tubes are V3 (left) and V6 (right). (Refer to the tube numbers printed adjacent to pin #1 of each tube on the printed circuit board.)

If the undesirable noise increases as you turn up the volume control, the faulty tube is likely to be one of the phono section tubes.

An easy way to determine if a tube in any particular position is causing undesirable noise is to swap the suspected tube with its counterpart in the opposite channel. If the noise jumps to the other channel, the tube you suspected is indeed faulty.

Bob01605@aol.com

Minimizing Noise in the System

Hum is caused by amplification of the 50 or 60Hz AC power line signal which is transmitted via the magnetic fields around power transformers and power cables. RF interference usually comes from inadequate shielding of cables or components. If any of these types of noises are encountered, one or more of the following pointers concerning proper component positioning and grounding may be of use:

- Ensure that each system component, especially the preamp, is located far enough away from the other components so as to not pick up hum from them and that the AC power cables are not in close proximity to audio cables.
- Ensure that all audio cables are securely pushed into their respective jacks. A faulty audio cable, although rare, can be a source of hum if its outer shield is broken or disconnected from an RCA plug at one end of the cable.
- Generally the best system grounding scheme is to have the preamplifier well grounded to an earth ground point and function as the system's main ground reference. Other system components are then quite adequately grounded via their audio cables to the preamp's ground. This can be as simple as plugging the preamp's power cable into a three-prong AC outlet. However, if the AC outlet itself does not provide a really "good" ground, then the power cable can be plugged into a 3-to-2 prong adapter and a wire can be run from the tab on the adapter to the nearest cold water pipe.

Other proven solutions to AC power cable "ground loop" hum problems have been: 1) Reverse the way the cable is plugged in (polarity) if it is a 2-prong plug. 2) Plug all AC power cables into a common "socket strip". 3) "Defeat" or deactivate the power cable grounds for one or more components (especially power amplifiers) by plugging those power cables into un-grounded 3-to-2 prong adapters.

- If RF noise (usually an AM radio station or CB radio transmission) is a problem in your location, an AC power filter can be purchased into which some or all of your system power cords can be plugged. This is done if the RF is coming in through the building's AC wiring. However, if RF gets into the system via your turntable, you may have to use tonearm cables with better shielding. (This is tested by unplugging the turntable from the system and putting "shorting plugs" in the preamp's phono inputs before listening again.) RF noise is sometimes eliminated by simply moving the turntable or other components to another location in the room.
- Hum from a turntable is usually traced to an adjacent power transformer or a missing ground. Check to see that the turntable motor is grounded via a wire to the preamp's grounding post - or try removing this wire from the ground post if it's already there.

Bob01605@aol.com

PAS-4 Specifications:

Phono Section:

GAIN: ----- 40 dB
RIAA ACCURACY: ----- +/- .5 dB from 20 Hz to 20 kHz
PHONO OVERLOAD: ----- 500mV RMS @ 1kHz
MAXIMUM OUTPUT CAPABILITY: ----- 60V RMS @ 1kHz
50V RMS @ 20kHz (for 1% THD)
THD: ----- less than .025% @ 2V RMS Output
INPUT IMPEDANCE: ----- 47k shunted by 10pF
TAPE OUTPUT IMPEDANCE: ----- 2k
NOISE: ----- -86 dB below 10mV RMS Input
ABSOLUTE PHASE: ----- Non-Inverting
TUBE COMPLEMENT: ----- 2ea 6DJ8/6922; 2ea 12AX7/ECC83

Line Section:

GAIN: ----- 18.5 dB
FREQUENCY RESPONSE: ----- 2 Hz to 150 kHz (nominal)
(-3 dB, 20 k ohm load)
MAXIMUM OUTPUT: ----- 40V RMS (for 1% THD)
THD: ----- .025% @ 2V RMS Output
INPUT IMPEDANCE: ----- 25k nominal (all inputs)
OUTPUT IMPEDANCE: ----- 40 ohms
NOISE: ----- -90 dB below 2V RMS Output
ABSOLUTE PHASE: ----- Inverting
SLEW RATE: ----- 40 Volts per Microsecond
TUBE COMPLEMENT: ----- 2ea 6DJ8/6922

Physical:

POWER REQUIREMENTS: ----- 117 VAC 50 - 60 Hz
230 VAC 50 - 60 Hz (export models)
100 VAC 50 Hz (Japan)
POWER CONSUMPTION: ----- 45 Watts / *0.375 Amps*
DIMENSIONS: ----- 17" wide, 3.75" high, 12" Deep
NET WEIGHT: ----- 12 lbs.
SHIPPING WEIGHT: ----- 14 lbs.
MADE IN THE U.S.A.

Bob01605@aol.com

Warranty

For three years from the date of purchase (1 year for tubes) Dynaco will repair for the original owner any defect in materials or workmanship that occurs in normal use, without charge for parts or labor.

It is the owner's responsibility to provide transportation to the authorized Dynaco service representative who will perform warranty service, and to present proof of purchase in the form of your dated sales slip when requesting service.

Excluded from this warranty is damage that results from abuse, misuse, accidents, shipping, or repairs or modification by anyone other than an authorized Dynaco service representative. This warranty is void if the serial number has been removed or defaced. This warranty gives you specific legal rights, and you may also have rights which vary from state to state.

If service is required, contact the dealer from whom you purchased the amplifier. If that is not possible, write Dynaco, giving us:

- Your name and address
- The preamplifier's serial number
- When and where you purchased it (copy of sales slip)
- Make and model of your amplifier
- Description of the problem
- Whether you have the original carton and fillers or need new ones

For best results, DYNACO strongly recommends using only its performance checked pre-tested vacuum tubes. Each tube is guaranteed to perform properly in its intended application for ONE YEAR. Orders for tubes may be paid for by personal check or money order. Please also include \$4.00 for shipping and handling.

DYNACO

A Division of Panor Corporation

125 Cabot Court
Hauppauge, NY 11788

(516) 434-1200
(516) 434-1457 FAX

Bob01605@aol.com

PAS 4 PC Board Parts List

<u>DESIGNATORS</u>	<u>DESCRIPTION</u>
	<i>Resistors</i>
R216, 220	.47 ohm, 3W
R201	100 ohm, 1/2W
R28, 128	140 ohm, 1/2W
R21, 25, 121, 125	221 ohm, 1/2W
R12, 112	249 ohm, 1/2W
R9, 11, 20, 23, 109, 111, 120, 123	301 ohm, 1/2W
R208, 211 thru 215, 218, 219	470 ohm, 1/2W
R202	470 ohm, 3W
R4, 104	1.37K, 1/2W
R1, 2, 101, 102	2.0K, 1/2W
R18, 118	5.6K, 1/2W
R8, 108	6.49K, 1/2W
R26, 126	15K, 3W
R206	20K, 1/2W
R19, 119	24.9K, 1/2W
R205	30K, 1/2W
R3, 103	47K, 1/2W
R10, 110	165K, 1/2W
R6, 106	249K, 1/2W
R5, 105	287K, 1W
R22, 122	301K, 1/2W
R203	332K, 1/2W
R13, 27, 113, 127	499K, 1/2W
R209, 210	1M, 1/2W
R204	1M, 1W
R7, 24, 107, 124	2M, 1/2W
R207	10M, 1/2W
R217	4.02M, 1/2W
	<i>Capacitors</i>
C1, 101	10pF, 630V, polystyrene
C2, 102	22pF, 630V, polystyrene
C4, 5A, 5B, 104, 105A, 105B	220pF, 400V, polypropylene 5%
C6, 106	1500pF, 400V, polypropylene 5%
C201, 203, 204	.01uF, 1.4 kV, ceramic disc
C3, 8, 103, 108	.1uF, 400V, polypropylene
C7, 9, 107, 109, 208-212, 214-218	1.0uF, 400V, polypropylene
C222	10.uF, 25V, alum electrolytic
C220, 223	22uF, 25V, alum electrolytic
C213	22uF, 250V, alum electrolytic
C205, 206	33uF, 450V, alum electrolytic
C221, 224	470uF, 25V, alum electrolytic
C207	1000uF, 6.3V, alum electrolytic
C219	4700uF, 25V, alum electrolytic

Bob01605@aol.com

DESIGNATORSDESCRIPTION

D1 thru D12	Semiconductors
ZD1, 3, 5, 7, 9, 11	1N4007 (1A, 1kV)
ZD2, 4, 6, 8, 10, 12	1N5242B (12V, 1/2w Zener)
FWB1	1N5388 (200V, 5w Zener)
U1, 3	GBPC6005 (6A, 50 PIV Bridge Rectifier)
U2	7812 (regulator)
D13	555 (timer)
Q1 thru Q6	LED, Bi-Color, (red/green)
	IRF 830 (N-Channel FET)
	Tubes
V1, 4	12AX7 (ECC83)
V2, 3, 5, 6	6DJ8 (6922)
	Switches
SW7 (AC power)	Switch, pushbutton, 2 pole / 2 position
SW4/ 5 (stereo/mono, EQ)	Switch, pushbutton, dual 2 pole / 2 position
SW1 (input selector)	Switch, rotary, 2 pole / 5 position P/N 333125
SW2 (tape dubbing)	Switch, rotary, 4 pole / 3 position P/N 333124
SW3 (tape monitor)	Switch, rotary, 2 pole / 3 position P/N 333124
	Misc.
P1	25K, dual VOLUME potentiometer
P2	25K, dual BALANCE potentiometer
K1	Relay (DPDT) P/N DS2YE-S-DC12V
FB1, 2	Ferrite Beads P/N 20010-3B
F1	Fuse, 2A fast Blow (1A for 230V)
JA1, 2, 3, 4, 5, 7	RCA Jack Assembly - 2x2 P/N RJ-PCM-204
JA6	RCA Jack Assembly - 1x2 P/N RJ-PCM-102

Bob01605@aol.com

Bob01605@aol.com

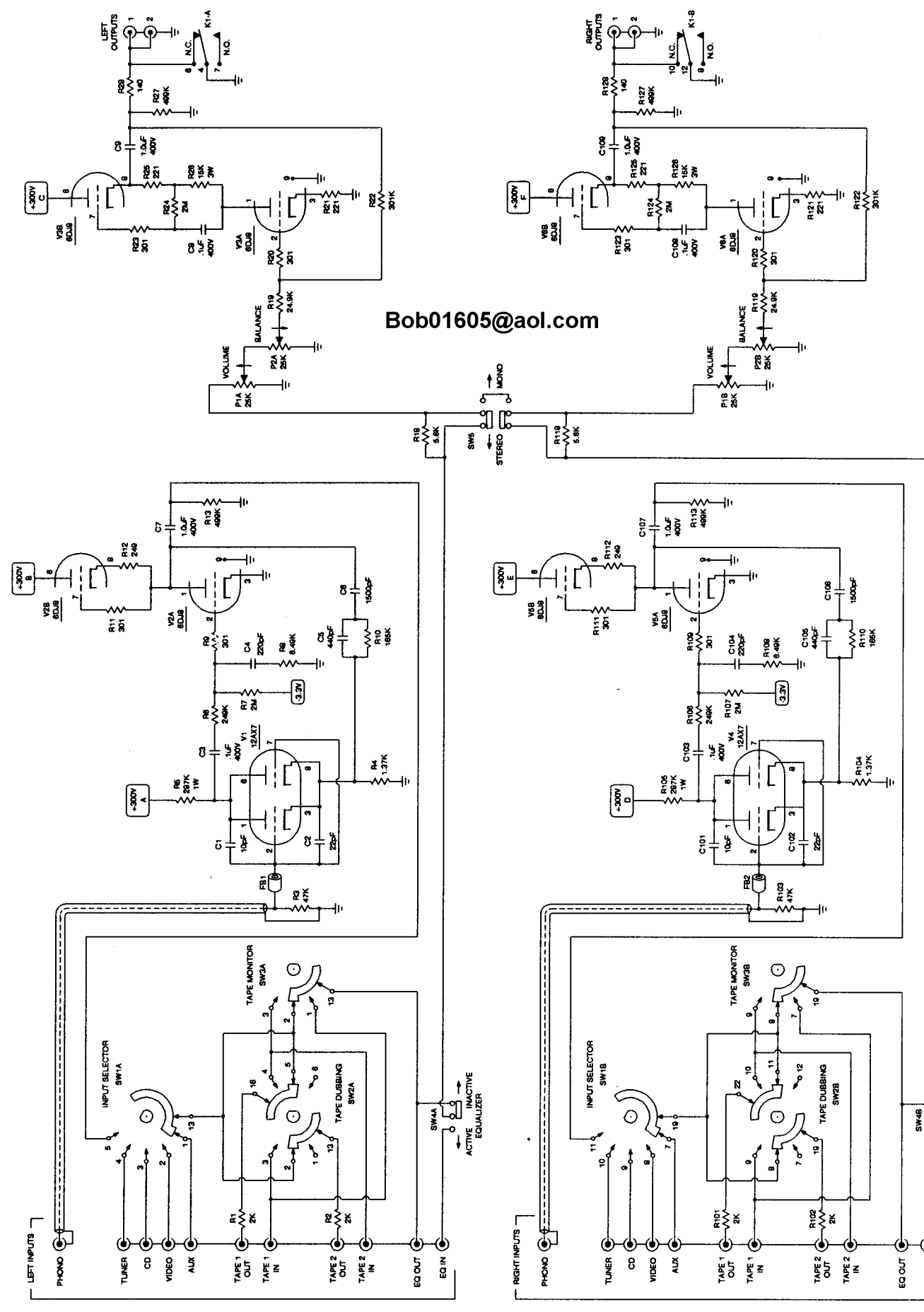

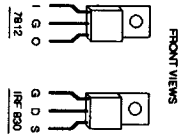
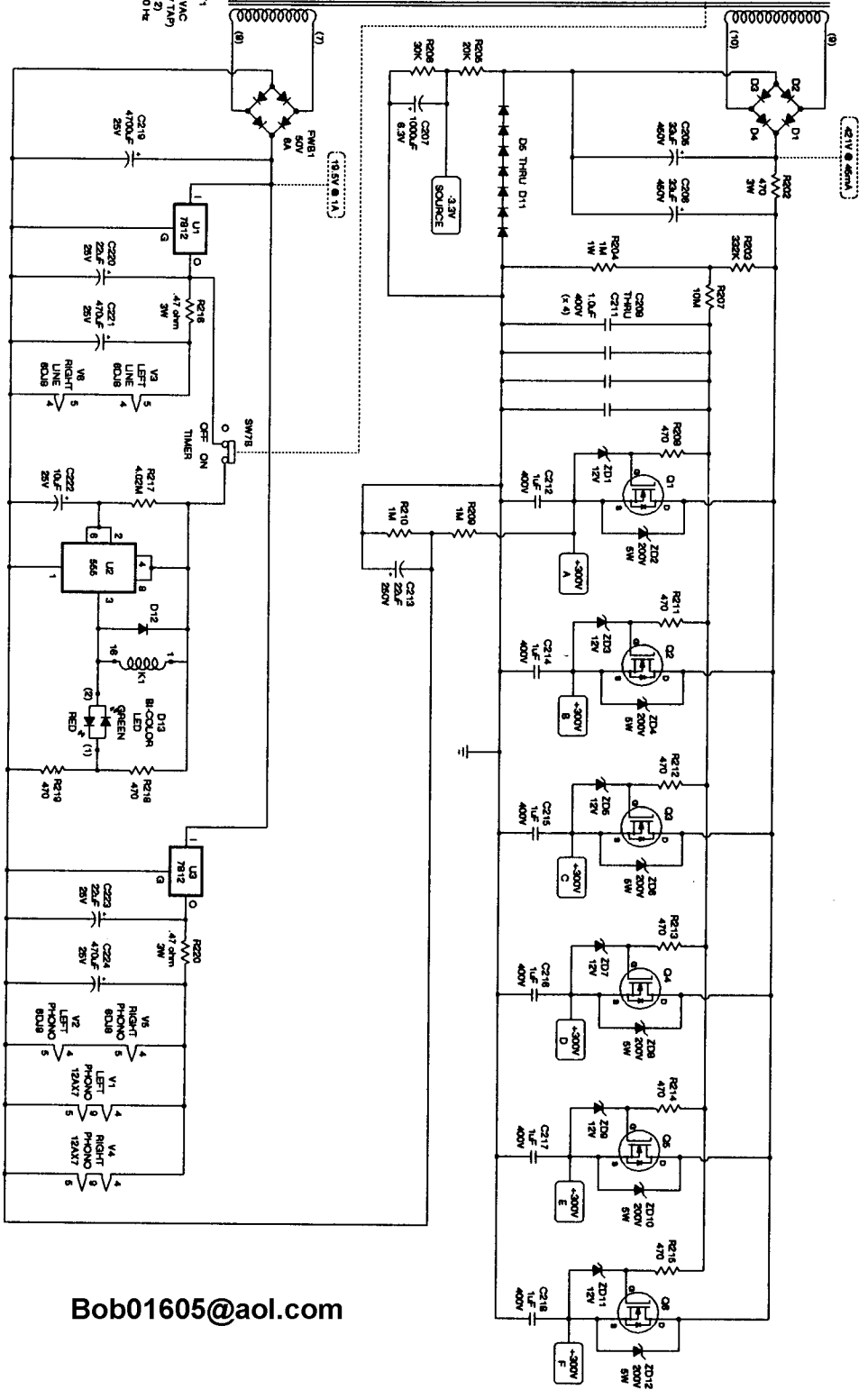
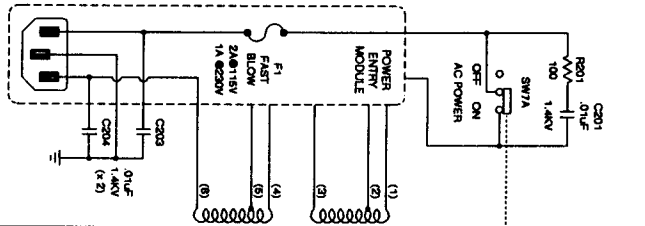

- D1 - D12 = 1N4007
- ZD1, 3, 5, 7, 9, 11 = 1N6242B
- ZD2, 4, 6, 8, 10, 12 = 1N6388B
- O1 - O6 = IRE B30

Bob01605@aol.com