

PHOTOFACT\* Folder

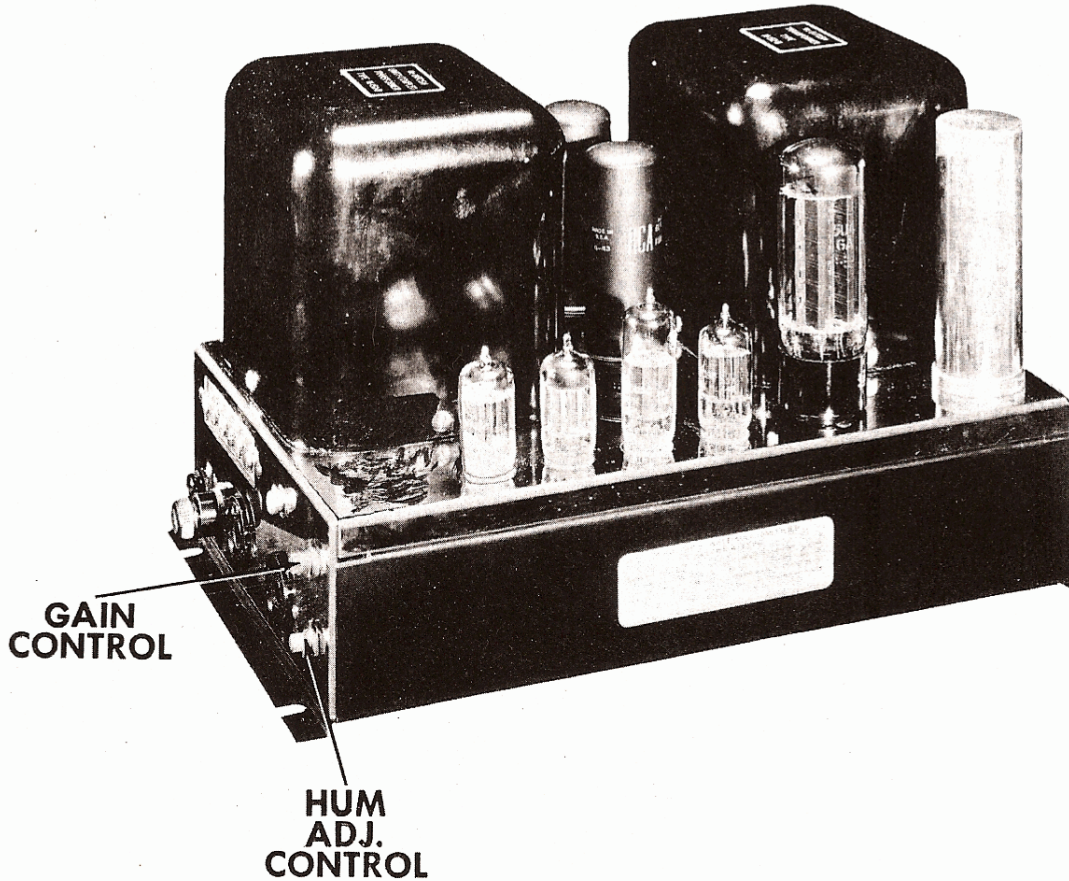

MC INTOSH  
MODEL MC-30

MC INTOSH  
MODEL MC-30



MC INTOSH  
MODEL MC-30

TRADE NAME	Mc Intosh Model MC-30
MANUFACTURER	Mc Intosh Laboratory, Inc., 320 Water St., Binghamton, N. Y.
TYPE SET	AC Operated 30 Watt Audio Amplifier
TUBES (Seven)	Types 12AX7 Preamp., 12AU7 AF Amp.-Phase Inverter, 12BH7 Driver, 12AX7 Driver, (2) 1614 Output, 5U4GA Rectifier
POWER SUPPLY	117/125 Volts AC-50/60 Cycles      RATING 1.03 Amp. @ 117 Volts AC

**HOWARD W. SAMS & CO., INC. • Indianapolis 5, Indiana**

"The listing of any available replacement part herein does not constitute in any case a recommendation, warranty or guaranty by Howard W. Sams & Co., Inc., as to the quality and suitability of such replacement part. The numbers of these parts have been compiled from information furnished to Howard W. Sams & Co., Inc., by the manufacturers of the particular type of replacement part listed."  
"Reproduction or use, without express permission, of editorial or pictorial con-

tent, in any manner, is prohibited. No patent liability is assumed with respect to the use of the information contained herein. Copyright 1955 by Howard W. Sams & Co., Inc., Indianapolis 5, Indiana, U. S. of America. Copyright under International Copyright Union. All rights reserved under Inter-American Copyright Union (1910) by Howard W. Sams & Co., Inc."      Printed in U. S. of America

DATE 4-55

SET 275

FOLDER 9

# PARTS LIST AND DESCRIPTIONS

## TUBES (SYLVANIA, GENERAL ELECTRIC, WESTINGHOUSE)

MC INTOSH  
MODEL MC-30

## CHASSIS—TOP VIEW

ITEM No.	USE	REPLACEMENT DATA		RETMA BASE TYPE	NOTES
		MC INTOSH PART No.	STANDARD REPLACEMENT		
V1	Preamp/ifier	12AX7	12AX7	9A	
V2	AF Amplifier-Phase Inverter	12AU7	12AU7	9A	
V3	Driver	12BH7	12BH7	9A	
V4	Driver	12AX7	12AX7	9A	
V5	Output	1614	1614	7S	
V6	Output	1614	1614	7S	
V7	Rectifier	5U4GA	5U4GA	5T	

## CAPACITORS

Capacity values given in the rating column are in mfd. for Electrolytic and Paper Capacitors, and in mmfd. for Mica and Ceramic Capacitors.

ITEM No.	RATING		REPLACEMENT DATA					INSTALLATION NOTES	
	CAP.	VOLT	MC INTOSH PART No.	CENTRALAB PART No.	ERIE PART No.	MALLORY PART No.	PYRAMID PART No.		SANGAMO PART No.
C1A	.40	450				FP378	TM-804020-450	T-180	
C B	.80	450							
C C	.20	450							
C2	20	50				TC38	TD-25-50	FM-0825	
C3	10	450				TC72	TD-10-450	FM-4510	
C4	.1	400		DF-104		PT401	IMP4-P1	330401	
C5	.47	200				PT4047	IMP2-P47	3302047	
C6	470			D6-471	GP2K-471	UC-5347			
C7	.22	400				PT4022	IMP4-P22	3304022	
C8	.047	400		DF-503		PT4147	IMP4-S47	3304147	
C9	.047	400		DF-503		PT4147	IMP4-S47	3304147	
C10	.25	600				PT6025	IMP6-P25	3306025	
C11	.25	600				PT6025	IMP6-P25	3306025	
C12	.1	400		DF-104		PT401	IMP4-P1	330401	

## CONTROLS

ITEM No.	RATING		REPLACEMENT DATA					INSTALLATION NOTES
	RESISTANCE	WATTS	MC INTOSH PART No.	IRC PART No.	CLAROSTAT PART No.	CENTRALAB PART No.	MALLORY PART No.	
R1A	500K $\Omega$	$\frac{1}{2}$	6154455	QL1-133	A47-500K-S	AB-59	U-50	Gain
B	Shaft		Not Req.	Not Req.	FKS-1/4	AK-1	Not Req.	Attach to R1A
R2	250K $\Omega$	$\frac{1}{2}$	6154480	QL-201				Hum Adj.

## RESISTORS

ITEM No.	RATING		REPLACEMENT DATA		NOTES	ITEM No.	RATING		REPLACEMENT DATA		NOTES
	OHMS	WATT	MC INTOSH PART No.	IRC PART No.			OHMS	WATT	MC INTOSH PART No.	IRC PART No.	
R3	100K $\Omega$	$\frac{1}{2}$		BTS-100K		R18	220K $\Omega$	$\frac{1}{2}$		BTS-220K	
R4	27K $\Omega$	$\frac{1}{2}$		BTS-27K		R19	1200 $\Omega$	$\frac{1}{2}$		BTS-1200	
R5	3.3Meg	$\frac{1}{2}$		BTS-3.3Meg		R20	12K $\Omega$	2	*	BTB-12K	
R6	3300 $\Omega$	$\frac{1}{2}$		BTS-3300		R21	330K $\Omega$	$\frac{1}{2}$		BTS-330K	
R7	88 $\Omega$ 5%	$\frac{1}{2}$		BTS-88 5%		R22	220K $\Omega$	$\frac{1}{2}$		BTS-220K	
R8	100K $\Omega$	$\frac{1}{2}$		BTS-100K		R23	12K $\Omega$	2	*	BTB-12K	
R9	2200 $\Omega$ 5%	$\frac{1}{2}$		BTS-2200 5%		R24	100K $\Omega$ 5%	$\frac{1}{2}$		BTS-100K 5%	
R10	330K $\Omega$	$\frac{1}{2}$		BTS-330K		R25	1Meg	$\frac{1}{2}$		BTS-1Meg	
R11	1Meg	$\frac{1}{2}$		BTS-1Meg		R26	820K $\Omega$ 5%	$\frac{1}{2}$		BTS-820K 5%	
R12	1.2Meg	$\frac{1}{2}$		BTS-1.2Meg		R27	220K $\Omega$	$\frac{1}{2}$		BTS-220K	
R13	1Meg	$\frac{1}{2}$		BTS-1Meg		R28	1Meg	$\frac{1}{2}$		BTS-1Meg	
R14	18K $\Omega$	$\frac{1}{2}$		BTA-18K		R29	220K $\Omega$	$\frac{1}{2}$		BTS-220K	
R15	27K $\Omega$ 5%	$\frac{1}{2}$		BTS-27K 5%		R30	3300 $\Omega$	$\frac{1}{2}$		BTS-3300	
R16	2.2Meg	$\frac{1}{2}$		BTS-2.2Meg		R31	150 $\Omega$	10		PW10-150	
R17	3000 $\Omega$ 5%	$\frac{1}{2}$		BTS-3000 5%		R32	10K $\Omega$	2		BTB-10K	

\* R20 and R23 are matched within 1% when replacing.

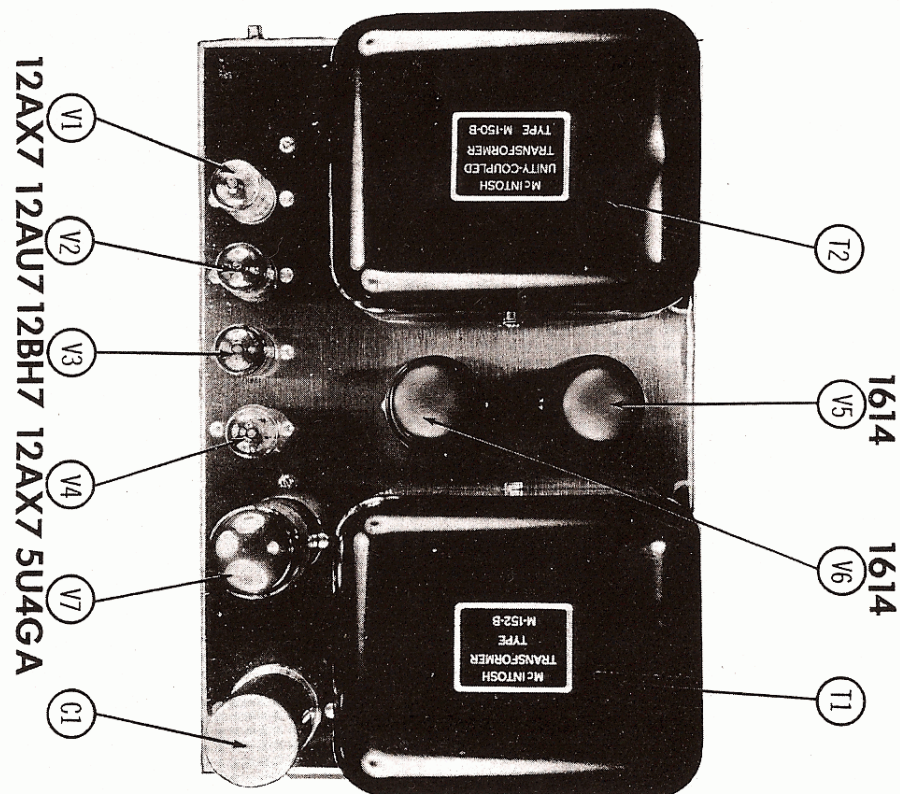

## PARTS LIST AND DESCRIPTIONS (Continued)

### TRANSFORMER (POWER)

ITEM No.	RATING				REPLACEMENT DATA					
	PRI.	SEC. 1	SEC. 2	SEC. 3	MC INTOSH PART No.	Stancor PART No.	Merit PART No.	Triad PART No.	Halldorson PART No.	Thordarson PART No.
	T1	117/125 VAC @ 1.03A	752VCT .110ADC	5VAC @ 3A	6.3VAC @ 3.3A	M-152-B	PC-8410①			

① Drill new mounting holes.

### TRANSFORMER (AUDIO OUTPUT)

ITEM No.	IMPEDANCE	REPLACEMENT DATA						NOTES		
		PRI. 1	SEC. 1	MC INTOSH PART No.	Stancor PART No.	Merit PART No.	Triad PART No.		Halldorson PART No.	Thordarson PART No.
		T2	1K $\Omega$ CT tap @ 30.4 $\Omega$ 36.4 $\Omega$ CT tap @ 30.4 $\Omega$	16 $\Omega$ tap @ 80.4 $\Omega$ RES SEC. 2 RES 1.4 $\Omega$	M-150-B					

### COILS (RF-IF)

ITEM No.	USE	DC RES.		REPLACEMENT DATA				NOTES
		PRI.	SEC.	MC INTOSH PART No.	MEISSNER PART No.	MERIT PART No.	MILLER PART No.	
		L1	RF Choke	1.2 $\Omega$			19-1001	
L2	RF Choke	2.2			19-1002		4606	2.7 Microhenries IRC part #CLA

### SELENIUM RECTIFIER

ITEM No.	RATING		REPLACEMENT DATA					NOTES
	CURRENT	MC INTOSH PART No.	FEDERAL PART No.	INTERNATIONAL PART No.	MALLORY PART No.	RADIO RECEPTOR PART No.	SARKES TARZIAN PART No.	
M1	.004ADC			8A25P	V-20HP			026-28H-Q

### FUSES

ITEM No.	TYPE	RATING	REPLACEMENT DATA					
			MC INTOSH PART No.		LITTELFUSE PART No.		BUSS PART No.	
			FUSE	HOLDER	FUSE	HOLDER	FUSE	HOLDER
M2	3AG	3A 250V			312002 (3AG -3A)	342001	AGC 3	HKP

## CHASSIS—BOTTOM VIEW

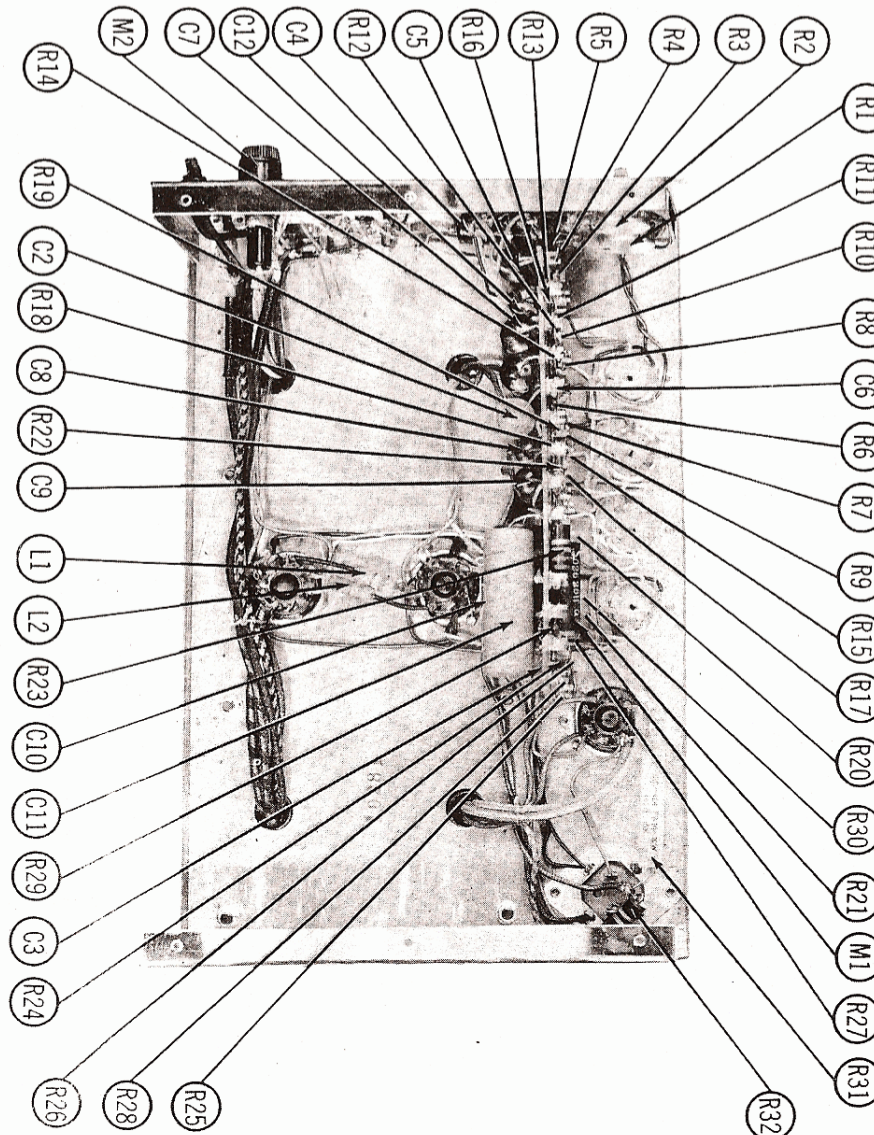

MC INTOSH  
MODEL MC-30

MC INTOSH  
MODEL MC-30

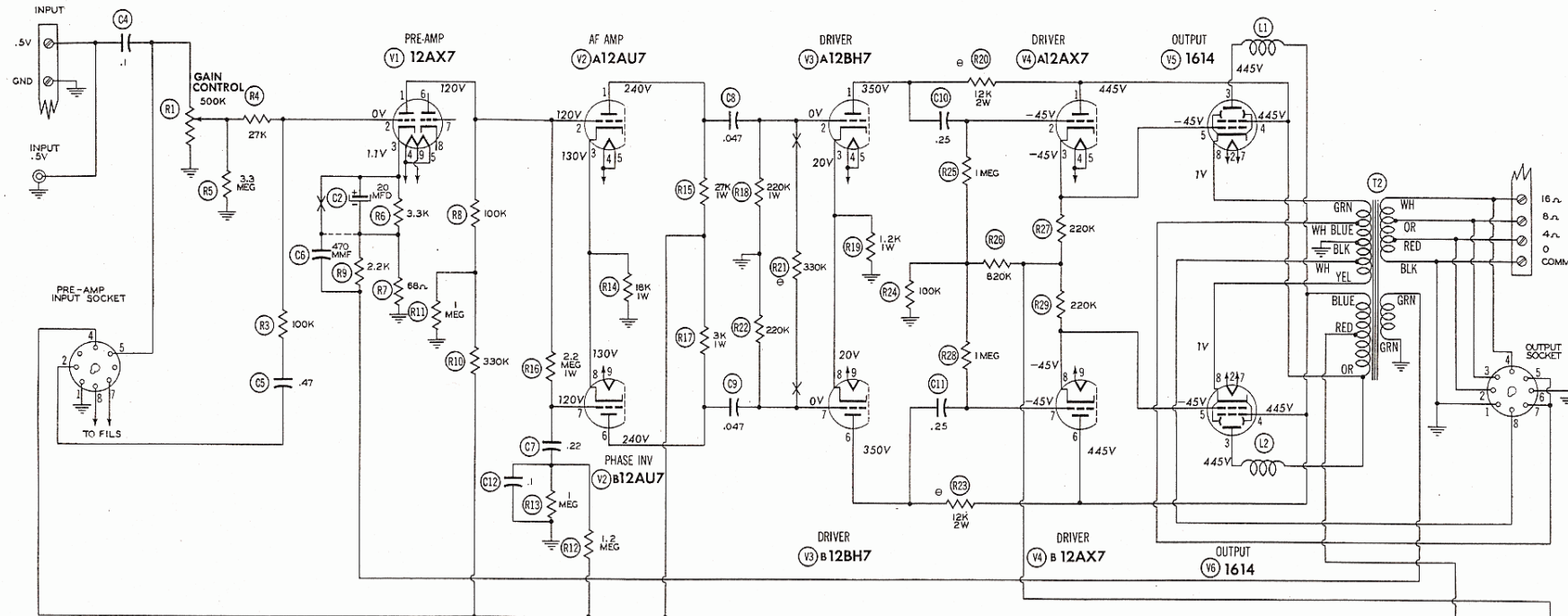

SEE PARTS LIST FOR ALTERNATE VALUE OR APPLICATION

RESISTANCE READINGS

Item	Tube	Pin 1	Pin 2	Pin 3	Pin 4	Pin 5	Pin 6	Pin 7	Pin 8	Pin 9
V 1	12AX7	1650KΩ	30KΩ	3.5KΩ	45Ω	45Ω	NC	NC	NC	45Ω
V 2	12AU7	138KΩ	1650KΩ	18KΩ	45Ω	45Ω	140KΩ	14.5Meg	18KΩ	45Ω
V 3	12BH7	12.8KΩ	220KΩ	1.2KΩ	45Ω	45Ω	12.6KΩ	220KΩ	1.2KΩ	45Ω
V 4	12AX7	1200Ω	1.1Meg	1Meg	45Ω	45Ω	1200Ω	1.1Meg	1Meg	45Ω
V 5	1614	0Ω	45Ω	1200Ω	1200Ω	850KΩ	NC	45Ω	15Ω	
V 6	1614	0Ω	45Ω	1200Ω	1200Ω	850KΩ	NC	45Ω	20Ω	
V 7	5U4GA	NC	85KΩ	NC	45Ω	NC	45Ω	NC	85KΩ	

NC - NO CONNECTION  
 TP - TIE POINT  
 † MEASURED FROM PIN 2 OF V7

- DC voltage measurements taken with vacuum tube voltmeter; AC voltages measured at 1000 ohms per volt.
- Socket connections are shown as bottom view.
- Measured values are from socket pin to common negative.
- Line voltage maintained at 117 volts for voltage readings.
- Nominal tolerance on component values makes possible a variation of ± 1% in voltage and resistance readings.
- All controls at minimum, proper output load connected.

