

dynakit
STEREO 70

SERIAL NUMBER

This number must be mentioned in all communications concerning this equipment.

INSTRUCTIONS FOR ASSEMBLY OPERATION

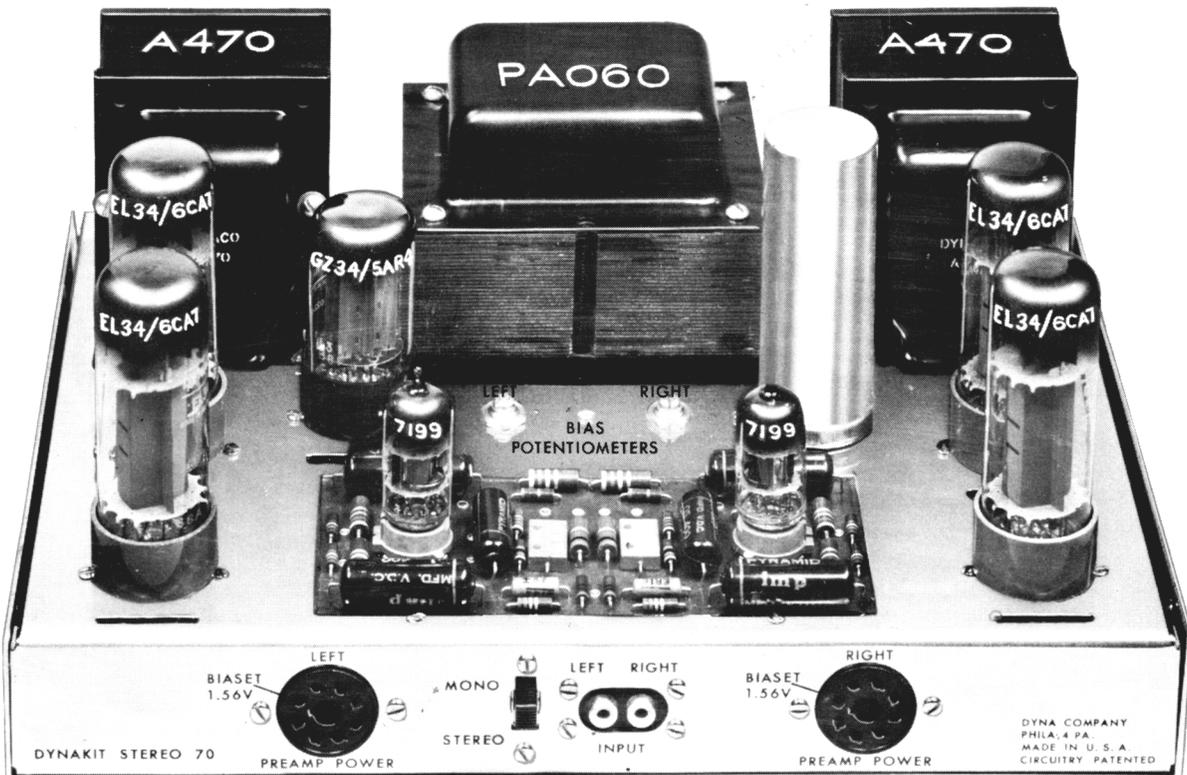

Price \$1.00

SPECIFICATIONS

Power Output	35 watts continuous, 80 watts peak each channel
Frequency Response	$\pm .5$ db from 10 cps to 40 kc
Power Response	20 cps to 20 kc within 1 db of 35 watts at less than 1% distortion
Intermodulation Distortion	Less than 1% at 35 watts (normally about .5%). Less than .05% at 1 watt
Hum and Noise	Inaudible; better than 90 db below rated power
Sensitivity	1.3 volts rms input for 35 watts out
Output Impedances	4, 8, 16 ohms each channel
Damping Factor	15
Minimum Channel Separation	55 db
Power Consumption	190 watts 50/60 cps
Preamp Provision	Two power takeoffs with independent heater windings to eliminate interaction. Each 6.3 volts 1 amp, 350 volts dc 10 ma. Dynakit pre-amplifiers plug in directly without modification.
Tube Complement	EL-34 (4), 7199 (2), GZ-34/5AR4, selenium rectifier.
Size	13" by 9-1/2" by 6-1/2" high
Weight	32 pounds
Finish	Chassis and bottom plate bright nickel plated. Cover finished in charcoal brown vinyl paint.

INSTRUCTIONS FOR ASSEMBLING THE DYNAKIT STEREO 70

DESCRIPTION

Your Dynakit Stereo 70 is a complete dual 35 watt power amplifier kit which offers the highest possible fidelity, at low cost and in a compact arrangement. It uses a patented circuit of outstanding performance characteristics, along with top quality parts, including the new Dynaco Super-Fidelity A-470 transformers -- the finest available. The measured specifications show that the Stereo 70 is an amplifier of unequalled performance, and its listening quality is also unrivalled by any regardless of price.

This amplifier has characteristics and power rating ideal for either stereophonic or monophonic use. The two non-interacting 35 watt channels provide adequate power, in a stereophonic or two channel system, for loudspeakers of any level of efficiency. The channels can be paralleled for a full 70 watts of low distortion output, suitable for practically any monophonic use even where several loudspeakers are in use in different areas. The high power capability and low internal impedance provide excellent damping for all types of high quality speaker systems without need to make adjustments to match specific speaker installations.

The design features of your Dynakit which contribute to its superior listening quality include some which are not revealed by the customary steady-state laboratory measurements. For example, the Stereo 70 does not exhibit bounce and flutter when pulsed with a transient signal. Thus a sharp percussive signal like a drum beat or a piano note will be reproduced with sharpness and clarity and neither overhang nor muddiness. The Stereo 70, unlike many other amplifier circuits, has been designed to provide its specified performance on a loudspeaker load, not just under laboratory measuring conditions. Therefore, the connection of a loudspeaker to the amplifier does not deteriorate its performance or listening quality. In addition, due to the high quality of the output transformers used, the Dynakit's power handling capabilities are maintained over the entire audio band without the sharp rise in distortion which characterizes most amplifiers at the extremes of high and low frequencies.

The Stereo 70 uses a circuit arrangement based on that of the Dynakits Mark II and Mark III which has become world famous as one of superior quality while essentially simple and trouble-free. The new 7199 tube is used as a pentode high gain voltage amplifier directly coupled to a cathodyne phase inverter. All parameters are adjusted for minimum distortion. This type of phase inverter has the unique advantage that its operation is independent of tube aging so that no adjustments are required in maintaining optimum performance.

An internal capacitive feedback loop balances the phase inverter at the highest frequencies, and the arrangement provides accurately balanced driving signals to the output tubes. These tubes are type EL-34's (one pair for each channel) operating well below their maximum ratings. The output tubes use a fixed bias arrangement which is set through use of Dyna Biaset (pat pending) which provides optimum linearity of the tubes and minimizes the effects of unbalanced components. The connection of the output tubes includes a small percentage of screen loading which improves the regulation of the output stage and makes it comparatively uncritical of load impedance.

The impedance match and bias conditions utilized in the output stage provide minimum distortion over a very wide dynamic range. In addition, 20 db of negative voltage feedback lowers the distortion to an unmeasurable proportion at normal listening levels and to less than 1% intermodulation distortion at 35 watts output on each channel.

The use of a minimum number of phase-shifting stages along with careful transformer design makes it practical to have unconditional stability at both high and low frequencies. This feature of the design means that there is no tendency toward motorboating or oscillation under any condition of use.

The inherent linearity of the circuit, the complete stability, and the prefabrication of all critical wiring on the printed circuit assembly make construction completely non-critical. The use of conservatively operated, highest quality components insures superior and dependable operation over a long period of time.

GENERAL WIRING PRACTICE

Assembly of the Dynakit Stereo 70 is quite simple compared to general kit assembly requirements. This is true because all critical parts of the Dynakit are factory assembled for you on the printed circuit assembly. Other parts are put out in the open through a free and uncluttered layout so there is easy accessibility for wiring or trouble shooting purposes. Construction of your Dynakit should not take more than about five hours because of these simplifications.

Upon opening your kit, check the components with the parts list. Familiarize yourself with the components; they can be identified by comparison with the pictorial diagram and by specified color coding. Proper color coding will be mentioned for each resistor as it is used.

Tools required for easy assembly of your Dynakit are soldering iron (small tip) or soldering

gun, long nose pliers, screwdriver, and wire cutters. Although not essential, a low cost wire stripper and cutter of the type which can be purchased for less than \$1.00 will greatly facilitate cutting and stripping the various leads in the kit.

Good soldering technique is valuable in obtaining satisfactory results from any electronic equipment. **ALL SOLDERING MUST BE DONE WITH ROSIN CORE SOLDER.** There is no warranty on any equipment in which acid core solder has been used. Make sure that the solder used is plainly marked "Rosin Core." If you have solder on hand the origin of which is doubtful it is wise to obtain new 50/50 or 60/40 rosin core solder. Whenever soldering is required, the assembly instructions specify it by "(S)." If this symbol is not shown after a connection is specified, it indicates that further connections will be made at that point before soldering.

Soldering is accomplished by heating the joint with the iron until solder is hot enough to flow when touched to the joint. It is not desirable to feed the solder to the iron. It should be fed to the junction of iron and joint. After the solder flows, the iron should be held in place for a few seconds and removed when it is seen that the solder has contacted both parts of the connection - the lug and the wire to which it is connected. It should not show a ball of solder but a smooth transition from solder to component lead.

Before applying solder the joint should be clean and the lead should be crimped in place so as to have mechanical security. It is not necessary to wrap leads around contacts many times. A single turn and pinching together with long nose pliers is suitable. After soldering, there should be no play at the joint if the lead is wiggled with a pair of pliers. It is practical to do all soldering with a pencil type iron of low wattage rating. A small tip is extremely useful when working in a confined space. If a soldering gun is used, it should be used with discretion since the amount of heat available is far more than required for soldering light wires.

Component leads should be trimmed as they are used; the length should be such that the proper connection can be made from point to point without strain on lugs or components. Care should be exercised not to allow wires to touch one another unless they are actually connected to the same point.

The instructions which follow have been arranged for simplified procedure in which the work can be done without interference between the various portions of the wiring. It is recommended that the instructions be followed on a step by step basis, checking off each stage as it is completed. The pictorial diagrams should be used for refer-

ence and all connections checked against these before going on to the next stage. If the wiring is done methodically and each step checked carefully, your amplifier should work without difficulty as soon as it is completed.

MECHANICAL ASSEMBLY

PICTORIAL DIAGRAMS SHOULD BE CONSULTED DURING ALL PHASES OF ASSEMBLY

- 1 () Mount the seven octal sockets with 4/40 hardware (the smallest screws supplied). Note that there is a small slot or keyway in the center hole of each socket; be sure in each instance that this keyway is properly oriented as shown in the pictorial diagram. Insert screws from the top of the chassis and mount the sockets from the bottom. Fasten with nuts and lockwashers.
- 2 () Place the bakelite insulator over the front of the two socket input connector and mount the combination from the inside of the chassis using 4/40 hardware.
- 3 () Mount the SPDT slide switch (with three lugs) next to the input connector. No nuts or lockwashers are necessary since this item has threaded holes.
- 4 () Mount the two four screw terminal strips on the chassis rear from the outside. Fasten with 4/40 hardware.
- 5 () Mount the two 10,000 ohm potentiometers in the 3/8" holes near the center of the chassis. Locate with the three connecting lugs facing the front of the chassis. Put a 3/8" lockwasher on each shaft, insert from the inside, and fasten with a 3/8" nut.
- 6 () Fasten the long 4/40 screw between the two potentiometers with a 4/40 nut. Then place the selenium rectifier over the screw. The lug marked (+) should be closest to the chassis and both lugs should face the rear of the chassis. Fasten with 4/40 lockwasher and nut.
- 7 () Mount the rubber grommet in the 3/8" hole in the center of the rear flange of the chassis.
- 8 () Mount the fuse post in the D shaped hole in the rear of the chassis. The rubber washer goes between the chassis outside and the shoulder of the fuse post. Fasten with special nut provided.

WIRING PROCEDURE

EACH LENGTH OF HOOKUP WIRE SPECIFIED SHOULD HAVE APPROXIMATELY 1/4" OF INSULATION STRIPPED FROM EACH END UNLESS OTHERWISE SPECIFIED.

- 9 () Mount the SPST on-off switch (two lugs) on the chassis rear. The connecting lugs should be located as shown in the pictorial diagram. No lockwashers or nuts are necessary.
- 10 () Mount the power transformer, PA-060, in the large center cutout. The wires should face the front of the chassis. Fasten the two mounting screws at the rear with #8 lockwashers and nuts. Place a cable clamp over each of the two front mounting screws and fasten loosely with #8 lockwashers and nuts. The green, red, and white pairs of wires should be threaded through the left cable clamp as should the green-yellow and brown-yellow ones. Pass the brown pair through the right clamp.
- 11 () Mount the choke, C-354, on the right side below the chassis. Put the #8 screws through the chassis from the top and fasten underneath with lockwashers and nuts. The leads should face the front of the chassis.
- 12 () Using 4/40 hardware, mount the seven lug terminal strip on the left side opposite the choke, following the position shown in the pictorial diagram.
- 13 () Mount both A-470 output transformers with #8 hardware. Note that the shorter leads come through the holes in the rear.
- 14 () Mount the quadruple section filter capacitor in the special cutout. Fasten by twisting each mounting tab one-quarter turn. Note that the four connecting lugs are identified by markings at the base of the lugs. Be sure to orient the capacitor properly, with the lugs positioned as in the pictorial.
- 15 () Mount two solder lugs with a #4 screw and nut next to the quad filter capacitor. This is the main grounding point of the entire amplifier and should be tightened securely with the two lugs pointing as shown in the pictorial.

MOST TRANSFORMER LEADS ARE PRE-CUT TO THE PROPER LENGTHS AND DO NOT REQUIRE CUTTING. HOWEVER, THEY CAN BE SHORTENED WHERE DESIRED. IT IS ESSENTIAL THAT THEY NOT BE CUT TOO SHORT FOR CONNECTIONS WHEN THE LEADS ARE POSITIONED IN ACCORDANCE WITH THE PICTORIAL DIAGRAM. IN THE EVENT THAT THE TRANSFORMERS ARE RETURNED TO THE FACTORY FOR REPLACEMENT OR INSPECTION, THE LEADS MUST BE OF USABLE LENGTH OR THE WARRANTY WILL BE VOIDED.

- 1 () Connect the red-black transformer lead to the lower (+) lug of the selenium rectifier (S).
- 2 () Twist the pair of white leads and dress them from the power transformer to socket V1. Connect one lead to pin #2 of V1 (S). Connect the other white lead to pin #8 of V1.
- 3 () Twist the red pair of leads and dress them to socket V1. Connect one red lead to pin #4 of V1 (S). Connect the other red lead to pin #6 of V1 (S).
- 4 () Twist the pair of green leads together and dress to socket V2. Connect one green lead to pin #2 of V2. Connect the other green lead to pin #7 of V2.
- 5 () Twist the brown pair and dress them to socket V7. Connect one brown lead to pin #2 of V7. Connect the other brown lead to pin #7 of V7.
- 6 () Dress the brown-yellow and green-yellow leads around to the seven lug terminal strip. Connect the brown-yellow to lug #7 and the green-yellow to lug #5.
- 7 () Connect the red-yellow lead to the solder lug near the filter capacitor.
- 8 () Feed the red lead from the left output transformer through both cable clamps and the red lead from the right output transformer through the right clamp. Connect both red leads to filter capacitor lug #1. (The lead from the right output transformer can be trimmed to the required length).
- 9 () Feed the two choke leads through the right cable clamp, connect one lead to filter capacitor lug #2 and the other lead to lug #1. (These leads can be trimmed as required). Tighten the two nuts holding the cable clamps.
- 10 () Dress the power transformer black leads around the end bell and connect one lead to lug A of the fuse post (S). Connect other black lead to lug #1 of on-off switch (S).
- 11 () Connect the short black lead from the right output transformer to lug #4 of the 4 screw terminal strip. Connect the brown lead to lug #3 (S). Connect the orange lead to lug #2 (S). Connect the yellow lead to lug #1.

- 12 () Repeat step 11 for the left output transformer and the left screw terminal strip.
- 13 () Twist the blue and green leads from the left output transformer together and connect the green lead to pin #4 of V3. Connect the blue lead to pin #3 of V3 (S). Twist blue-white and green-white together and connect the blue-white lead to pin #3 of V2 (S). Connect the green-white lead to pin #4 of V2 (S).
- 14 () Repeat step 13 for right output transformer. The blue lead is twisted with the green and goes to pin #3 of V6 (S), green to pin #4, while the blue-white and green-white, after twisting together, are connected to pins #3 (S) and #4 (S) of V7.
- 15 () Connect the center (common) lead of the double (2x.02) disc capacitor to lug #6 of the 7 lug terminal strip. Connect one of the outside wires to lug #5 of the strip (S) and the other outside wire to lug #7 of the strip (S).
- 16 () Twist together a pair of 6" wires except for 1-1/2" at each end. Connect one end of one wire to pin #2 of V7 (S). Connect the other wire to pin #7 of V7 (S). Connect one of the other ends to pin #2 of V6. Connect the remaining end to pin #7 of V6.
- 17 () Twist together a pair of 7" wires except for 1-1/2" at each end. Connect one end of one wire to pin #2 of V6 (S). Connect the other wire to pin #7 of V6 (S). Dress the pair to the front panel of the chassis and over to the right power takeoff socket. Connect one end of the pair to pin #1 of the takeoff socket. Connect the other of the twisted pair to pin #2 of the takeoff socket.
- 18 () Repeat step 16 for connection of V2 and V3.
- 19 () Repeat step 17 for connection of V3 to left power takeoff socket.
- 20 () Connect one end of a 5" wire to lug #1 of the 7 lug strip. Connect the other end to lug #6.
- 21 () Connect the negative end (-) of a 50 MFD capacitor to lug #4 of the seven lug strip. Connect the positive (+) capacitor lead to lug #1.
- 22 () Cut both leads of a 10,000 ohm (brown-black-orange) resistor to 1". Connect one end of the resistor to lug #4 of the 7 lug strip and the other end to lug #3.
- 23 () Connect the negative end of the other 50 MFD capacitor to lug #3 of the 7 lug strip and the positive end to lug #1.
- 24 () Cut both leads of another 10,000 ohm (brown-black-orange) resistor to 1". Connect one end to lug #2 of the seven lug strip. Connect the other end to lug #1 of the strip (S).
- 25 () Connect one end of a 6" wire to lug #6 of the 7 lug strip (S). Connect the other end to the ground lug near the filter capacitor. See pictorial.
- 26 () Connect one end of a 6" wire to lug #3 of the 7 lug strip (S). Connect the other end to lug #1 of the left bias potentiometer.
- 27 () Connect one end of a 6" wire to lug #4 of the 7 lug strip (S). Connect the other end to the negative (top) lug of the selenium rectifier (S).
- 28 () Connect one end of an 8" wire to lug #2 of the 7 lug strip (S). Connect the other end to lug #3 of the left bias control.
- 29 () Connect one end of a 3" wire to lug #3 of the right side bias potentiometer (S). Connect the other end to lug #3 of the left side bias potentiometer (S).
- 30 () Connect one end of a 3" wire to lug #1 of the right side bias potentiometer (S). Connect the other end to lug #1 of the left side potentiometer (S).
- 31 () Connect one end of a 5-1/4" wire to lug #8 of V1 (S). Connect the other end to lug #2 of the quad filter capacitor (S).
- 32 () Trim the leads of a 6800 ohm (blue-gray-red) resistor to 1". Connect one lead to lug #1 of the filter capacitor (S). Connect the other end to lug #4 of the filter capacitor.
- 33 () Connect one end of a 15.6 ohm resistor to the ground lug on base of V2 socket (S). Connect the other end to pin #8 of V2.
- 34 () Strip both ends of a 5" wire 1/2". Feed one end through pin #1 of V2 (S) and connect it to pin #8 of V2 (S). Feed the other end through pin #8 of V3 (S) and connect to pin #1 of V3.
- 35 () Connect one end of a 4-1/2" wire to pin #1 of V3 (S). Connect the other end to pin #8 of the left power takeoff socket (S).
- 36 () Connect one end of the other 15.6 ohm resistor to the ground lug at the base of socket V7 (S). Connect the other end to pin #1 of V7.

- 37 () Strip both ends of a 5" wire 1/2". Feed one end through pin #8 (S) and connect it to pin #1 of V7 (S). Feed the other end through pin #1 (S) of V6 and connect to pin #8 of V6.
- 38 () Connect one end of a 4-1/2" wire to pin #8 of V6 (S). Connect the other end to pin #8 of the right power takeoff socket (S).
- 39 () Connect one end of a 1000 ohm (brown-black-red) resistor to pin #5 of V2 (S). Connect the other end to pin #6. Repeat for V3, V6 and V7. Keep the resistor pigtailed short (about 1/2") for all four of these resistors.
- 40 () Mount the printed circuit board PC-3 from the bottom of the chassis. Note the numbers of the eyelets are upright when looking from the rear of the chassis. Use a 4/40 screw, lockwasher and nut at each mounting hole. The two wires from the board should be straightened carefully. These are used at a later step.
- In making solder connections to the printed circuit board, all connections are made to the numbered eyelets in the board. In this way, there is no danger of damaging the printed wiring or the components which are part of the board assembly. These eyelets already have solder in them and it is very easy to make solder connections to the board. The lead wires should have their ends stripped back about 1/4", and these stripped ends should be tinned by heating with a soldering iron and touching against the solder. When the wire is to be soldered to the eyelet on the board, the eyelet is heated until the solder flows; and then the wire end is pushed into the eyelet and held in place until the solder sets. This type of soldering can be done with a very small iron, and it is preferable not to use any more heat on the eyelet on the board than is required to get the solder to flow.
- 41 () Connect a 2-3/4" wire from eyelet #23 (S) of the printed circuit board to pin #6 of V6 (S).
- 42 () Connect a 3" wire from eyelet #22 (S) to pin #6 of V7 (S).
- 43 () Connect a 3" wire from eyelet #19 (S) to filter capacitor lug #3.
- 44 () Cut the leads of a 22,000 ohm (red-red-orange) resistor to 1". Connect one end of the resistor to capacitor lug #3 (S). Connect the other end to capacitor lug #4.
- 45 () Connect a 3-1/2" wire from eyelet #20 (S) to capacitor lug #4 (S).
- 46 () Observe two wires extending from the printed circuit board just under the input socket. Connect the extended wire on the right to the ground (short) lug of the right input socket. Connect the left extended wire to the ground (short) lug of the left input socket.
- 47 () Connect a 1-1/2" wire from eyelet #18 (S) to lug #5 of the right power takeoff socket (S).
- 48 () Twist together a pair of 3-1/4" wires. Connect one pair of ends to eyelets #15 (S) and #16 (S). Connect the other ends to pins #1 (S) and #2 (S) of the right power takeoff socket.
- 49 () Connect one end of a 10 ohm (brown-black-black) resistor from eyelet #10 (S) to pin #3 of the right power takeoff socket (S).
- 50 () Connect one end of a 2-1/2" wire to eyelet #21 (S). Connect the other end to lug #2 of the right potentiometer (S).
- 51 () Connect one end of a 5-1/2" wire to eyelet #14 (S), and connect the other end to pin #4 of V6 (S).
- 52 () Connect a 2" wire from lug #3 of the input switch (S) to the long lug of the right input socket.
- 53 () Connect one end of a 470,000 ohm (yellow-violet-yellow) resistor to long lug of right input socket. Connect the other end to the ground (short) lug of the right input socket (S).
- 54 () Connect one end of a 470,000 ohm (yellow-violet-yellow) resistor to lug #1 of the input switch (S). Connect the other end to the ground short lug of the left input socket (S).
- 55 () Connect one end of a 1-3/4" wire to eyelet #17 (S). Connect the other end to the long lug of the right input socket (S).
- 56 () Connect one end of a 3-1/2" wire to eyelet #7 (S). Connect the other end to the long lug of the left input socket.
- 57 () Connect a short link of wire from the left input socket long lug (S) to lug #2 of the input switch (S).
- 58 () Connect a 1-1/4" wire from eyelet #3 (S) to pin #5 of the left takeoff socket (S).

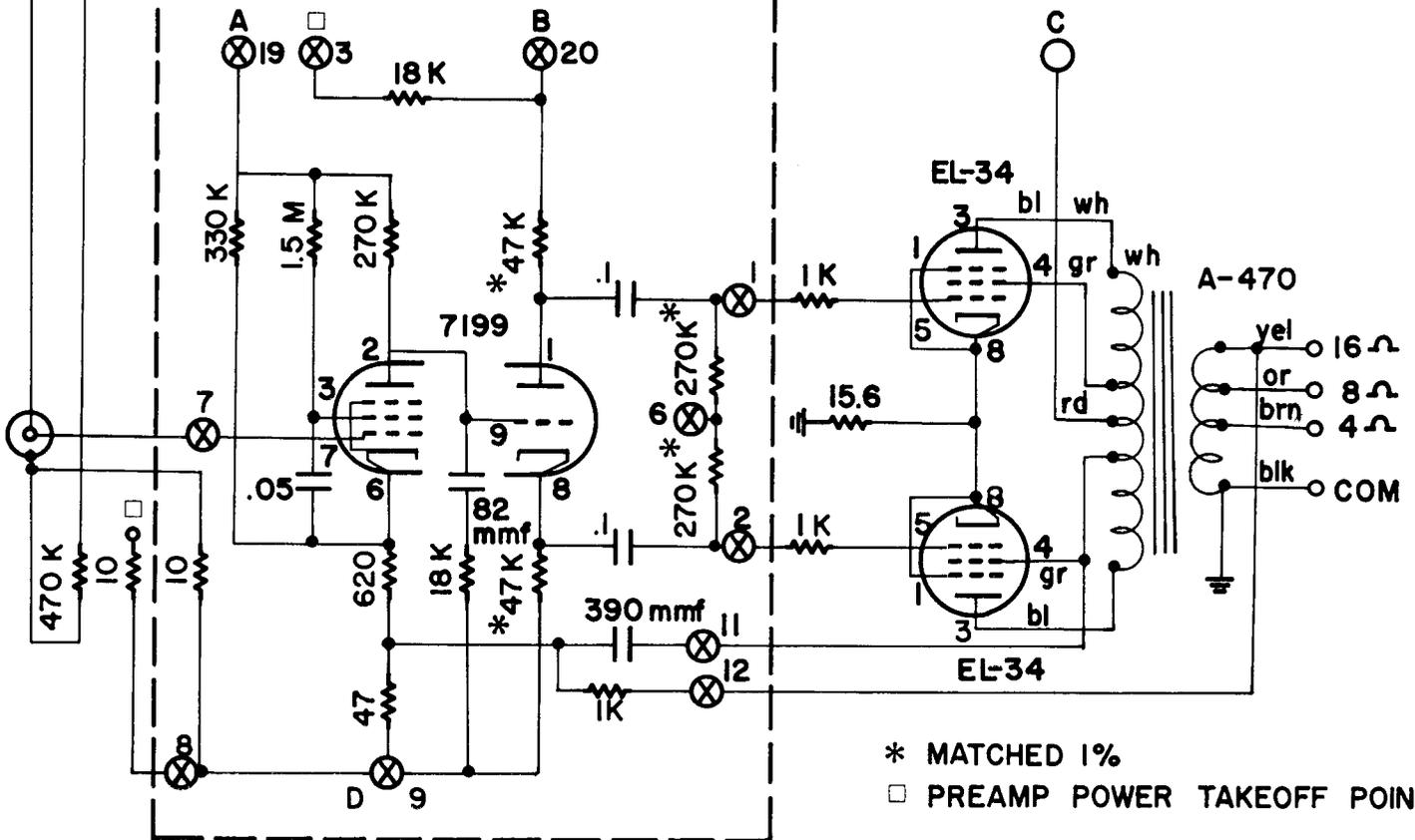
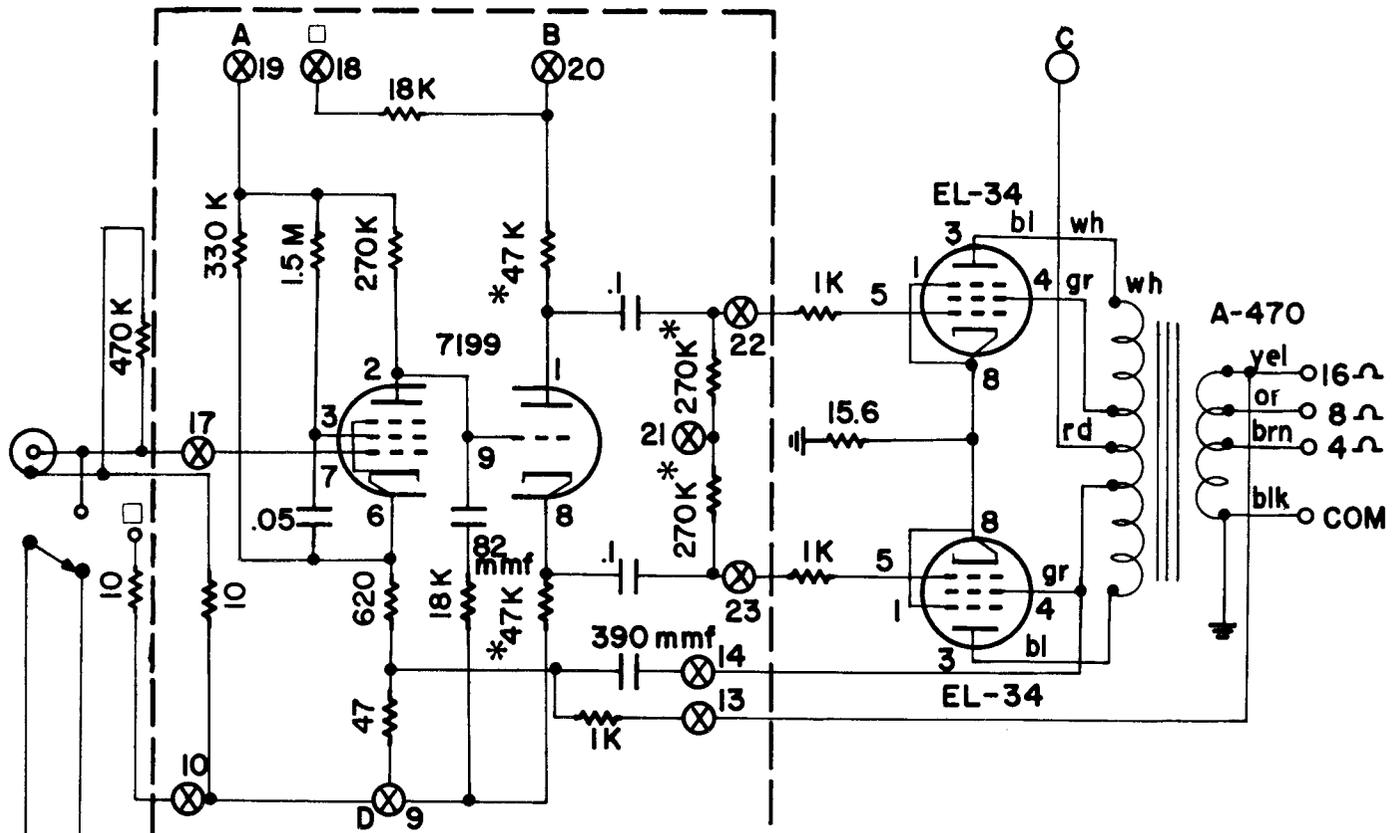

* MATCHED 1%

□ PREAMP POWER TAKEOFF POINTS

VOLTAGE TEST POINTS

Pin #	Any EL-34	GZ-34	Either 7199
1	1.56	—	*
2	—	435	*
3	410	—	*
4	415	360 ac	6.4 ac
5	-32**	—	1.0
6	-32**	360 ac	0
7	—	—	*
8	1.56	435	*
9	—	—	*

*Measurements at these points vary from tube to tube and do not indicate whether performance is normal.

**Measurements at these points can only be made with a vacuum tube voltmeter. The two tubes in a pair should have identical readings.

Capacitor lug	Selenium rectifier	Printed circuit
A ■ 305	Bottom (+) lug 50 ac	Eyelets #3 and #18
B ▲ 375	Top (-) lug -65 dc	370 volts dc
C 415		
D ● 435		

SPECIAL INSTRUCTIONS FOR OPTIONAL 120-240 VOLT POWER TRANSFORMERS

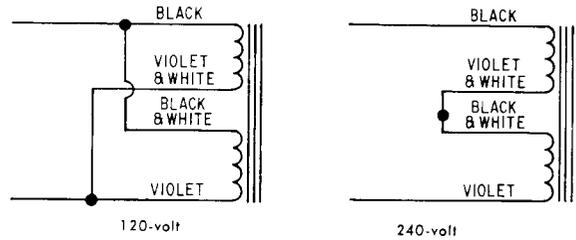

Stereo 70s supplied with power transformer PA-521 may be connected for either 120 volt or 240 volt AC operation as follows:

For 120 Volt Operation

- 1 () Twist together the black and black-white leads, and connect both to lug A of the fuse post (S).
- 2 () Twist together the violet and violet-white leads, and connect both to lug #1 of the on-off switch (S).

For 240 Volt Operation

- 1 () Connect the black lead to lug A of the fuse post (S).
- 2 () Connect the violet lead to lug #1 of the on-off switch (S).
- 3 () Twist together the violet-white and the black-white leads, and solder them together. Insulate this connection with electrical tape.

When connected for 240 volt operation, a 1½ ampere slow blow fuse should be used.

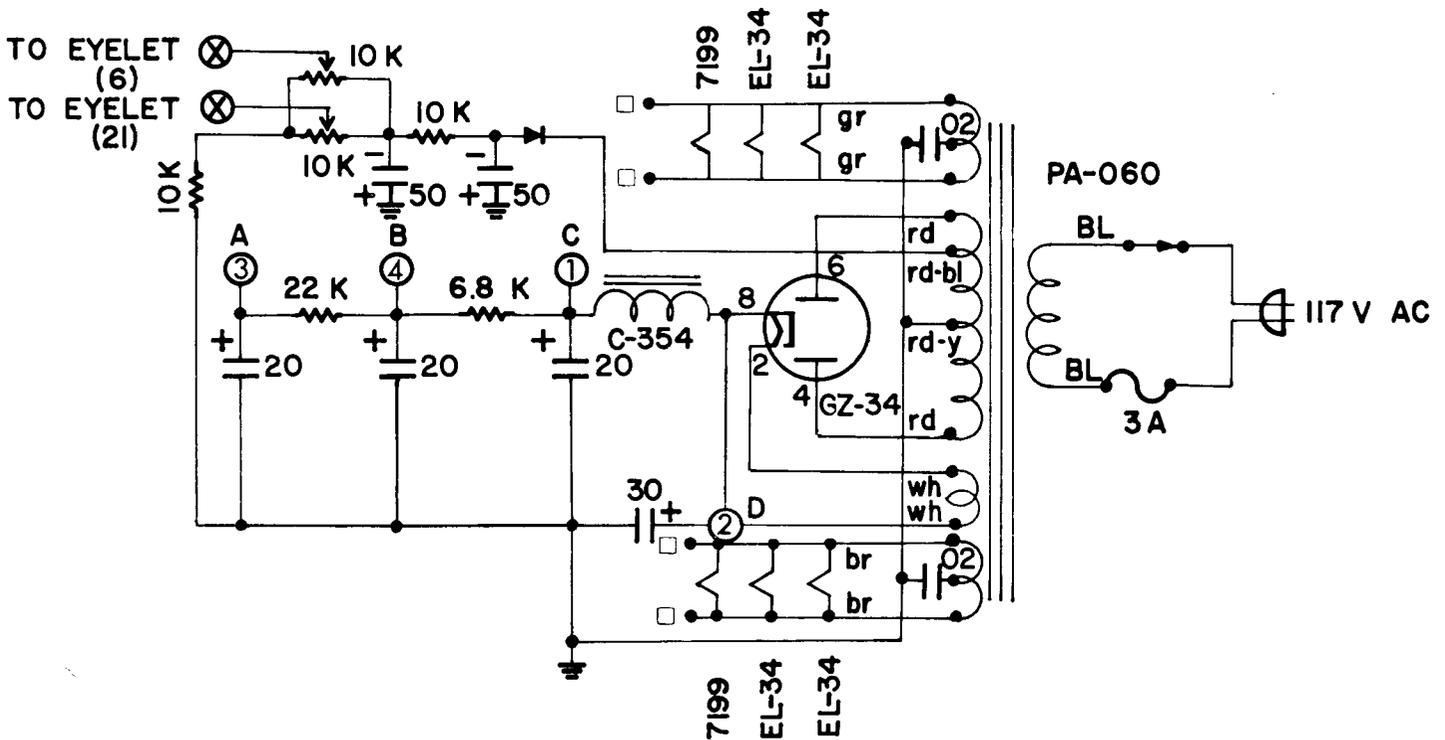

- 59 () Connect one end of a 10 ohm, (brown-black-black), resistor to eyelet #8 (S). Connect the other end to pin #3 of the left power takeoff socket (S).
- 60 () Twist a pair of 3-1/2" wires together and connect one pair of ends to eyelets #4 (S) and #5 (S). Connect the other pair of ends to pins #1 (S) and #2 (S) of the left power takeoff socket.
- 61 () Connect one end of a 2-1/2" wire to eyelet #2 (S). Connect the other end to pin #6 of V3 (S).
- 62 () Connect one end of a 3-1/2" wire from eyelet #1 (S). Connect the other end to pin #6 of V2 (S).
- 63 () Connect one end of a 2-1/2" wire to eyelet #6 (S). Connect the other end to lug #2 of the left potentiometer (S).
- 64 () Connect one end of an 8" wire to pin #4 of V3 (S). Connect the other end to eyelet #11 (S). It is important to keep this wire close to the chassis and carried around the printed circuit board as shown in the pictorial.
- 65 () Connect one end of a 5" wire to eyelet #9 (S). Connect the other end to solder lug near filter capacitor.
- 66 () Connect one end of a 12" wire to lug #1 of the left screw terminal strip (S). Connect the other end to eyelet #12 (S). See pictorial.
- 67 () Connect one end of a 10-1/2" wire to lug #4 (S) of the left screw terminal strip. Connect the other end to the solder lug near filter capacitor.
- 68 () Connect one end of a 9-1/2" wire to lug #1 of the right screw terminal strip (S). Connect the other end to eyelet #13 (S). See pictorial.
- 69 () Connect one end of a 9" wire to lug #4 (S) of the right screw terminal strip. Connect the other end to solder lug near capacitor.
- 70 () Connect short link of wire from capacitor ground lug (S) to solder lug near capacitor. Solder all six wires which go to the pair of solder lugs.
- 71 (, Insert the line cord through the grommet in the rear of the chassis. Pull through about five inches, tie a knot and then pull from the outside till the knot is against the grommet. Separate the two conductors of

the line cord to the knot then strip about 1/2" of insulation from each end. Connect one end to lug B of the fuse post (S). Connect the other end to lug #2 of the on-off switch (S). This completes the wiring of your amplifier.

It is wise to go back and check all connections for correctness and for good soldering. All hardware should also be checked for tightness. The fuse can now be installed in the fuse post on the rear of the chassis. The four rubber feet should then be pushed into the four holes in the bottom plate - from outside toward inside and seated with a twisting motion.

INITIAL ADJUSTMENT

Plug in the EL-34 tubes V2, V3, V6 and V7. Also plug the 7199 tubes into printed circuit sockets. Do not plug in GZ-34 rectifier tube. If an ohmmeter is available, measure resistance from capacitor lug #2 to ground. This should be in excess of one hundred thousand ohms. Inspect wiring to make sure that all joints are soldered and that no parts are shorting together. Plug line cord into 117 volt ac line and turn on switch. While tubes are warming up, set the bias adjusting potentiometers to the center of their rotation. This is approximately the correct setting and can serve as an emergency operating adjustment if no test instruments are available. (HOWEVER, OPERATION WITHOUT CORRECT BIAS ADJUSTMENT IS NOT RECOMMENDED AS IT RESULTS IN POOR PERFORMANCE AND PROBABLE DAMAGE TO COMPONENTS.)

Your Dynakit includes Dyna Biaset (patent pending) which greatly simplifies setting of the bias voltage. This can now be done with the most simple and inexpensive types of dc meters as long as they have a rating of 1000 ohms per volt or higher. The correct setting of the bias provides a total cathode current for each pair of EL-34 tubes of 100 ma. This current through the precision 15.6 ohm resistors produces a voltage drop of exactly 1.56 volts dc, and this voltage can be checked at pin #8 of each preamplifier power takeoff socket. 1.56 volts is also the voltage which is furnished by a "D" type flashlight dry cell. Thus any fresh cell of this type can be used for an accurate reference standard for bias setting.

The procedure for setting the bias is to measure the voltage output of a "D" type dry cell and note the meter reading. Then insert the positive meter probe in the pin #8 hole of the left preamplifier power socket (note that outside the chassis the pin numbers are counted counterclockwise from the keyway while inside the chassis they are counted clockwise). The negative meter probe

should touch the chassis. Plug in the GZ-34 rectifier tube, and in about 10 seconds there will be a current flow which will cause a meter deflection. As the rectifier warms up, the reading will increase. The left bias potentiometer should be adjusted until the meter reading at pin #8 is the same as across the dry cell (this reading will be 1.56 volts if the meter is of sufficient accuracy). This adjustment should then be made using the right bias potentiometer and measuring the voltage at pin #8 of the right power takeoff socket. Then repeat the setting for the left control and left set of tubes. There may be some drifting of the reading as the tubes heat, but this will stabilize within 15 minutes after which no further adjustment is required. Small variations will occur with line voltage changes. These will have no effect on performance. Although the setting is a semi-permanent one, at times of tube replacement or similar repair or maintenance work, resetting of the bias will preserve peak performance and keep distortion at an absolute minimum.

If in the course of bias setting it is found that the control range of the potentiometer is insufficient to obtain the correct setting, do not operate the amplifier until the cause of the difficulty has been established. Operation with incorrect bias can lead to damage to the output tubes and/or other components.

Note that the use of pin #8 as directed in the wiring instructions means that this pin cannot be used as a connection point for preamplifiers if the preamplifiers take power from the power takeoff sockets of the front panel. Most preamplifiers do not require the use of this pin. However, for those which do, some other pin must be used as a bias check point. If no other pin is available, the connection from pins #8 of V3 and V6 to the preamplifier power sockets must be omitted; and bias measurements should be based on voltages read directly at pin #8 of V2 or V3 for the left channel or pin #8 of V6 or V7 for the right channel.

PREAMPLIFIERS

The Dynakit Stereo 70 can be used with any conventional stereo or monophonic preamplifier, or pair of monophonic preamplifiers. Preamplifiers which contain their own built-in power supply can be used by connecting their audio cables to the input socket. Those units which require power from the amplifier can be readily used with the Dynakit provided that the power sockets on the front panel of the Dynakit are properly wired. The preceding instructions include the proper wiring for both Dynakit and Heathkit WA-P2 preamplifiers so that these can be inserted without modification. Should others requiring different socket connections be used, the socket wiring can be changed to suit their requirements

PROTECTIVE COVER

The protective cover which is supplied with the Stereo 70 has been designed to be both functional and good looking. It should be used on the amplifier if the amplifier is located where it can be inadvertently touched by anybody. There is voltage appearing above chassis on the printed circuit board which is not lethal, but which can give an uncomfortable shock. In addition, the tubes get hot in normal operation, and touching them can result in a minor burn. Therefore, the protective cover should generally be used.

The amplifier should be located where there is adequate ventilation - at least one foot of space above it and a few inches all around. The amplifier can be located away from other elements of the high fidelity system so there should be no need to put it in too confined a space. NEVER put anything on top of the cover which can obstruct air flow. Always use the amplifier with the tubes in vertical position.

The cover and bottom plate are affixed at the same time. The amplifier chassis should be set over the bottom plate, the cover lowered over the chassis, and then the three pieces are fastened together with the six sheet metal screws through the chassis sides.

USING THE STEREO 70

The Dynakit Stereo 70 is designed to be used in any of three different modes of operation: stereophonic use in which separate stereo channels are carried through the two sides of the amplifier; high-low frequency amplification where one channel carries the low frequencies and the other the high frequencies with a frequency dividing network ahead of the amplifier; and monophonic use with the two channels paralleled so that 70 watts of power are available.

Stereophonic amplification

In stereo use, the Stereo 70 provides 35 watts per channel. A stereo preamplifier's two output cables, or other left and right signals, are connected to the input jacks of the Stereo 70. The input switch is set to "stereo", and remains in that position whenever two input cables are connected, allowing the preamplifier to do all the switching. The right loudspeaker is connected to the "right" screw terminal strip between the "C" terminal and the terminal corresponding to the speaker's impedance. The left loudspeaker is similarly connected to the "left" terminal strip.

If there are two monophonic preamplifiers which require power from the amplifier, each is connected to the respective preamplifier power takeoff socket. As provided, these will accom-

modate Dynakit monophonic preamplifiers without modification.

The Stereo 70 can be turned on and off from the back panel switch, or this switch can be left in "on" position, and the amplifier switched from one of the switched ac outlets on the associated pre-amplifier.

High-Low frequency amplification

For this type of operation the input switch on the Stereo 70 should be put to "stereo" position. The low frequency output of the dividing or cross-over network should be fed to the left input, and the "left" loudspeaker output should be connected to the bass speaker. The high frequency output of the dividing or cross-over network should be fed through the right channel, and the tweeter connected to the "right" loudspeaker terminal strip.

Monophonic 70 watt amplification

For monophonic operation, the two channels of the Stereo 70 may be paralleled. For this, only one input cable is connected to either the left or the right input (but not both), the input switch is set to "mono", and the outputs are connected together. An insulated wire jumper should be connected from "C" to "C" on the screw terminal strips. Another insulated wire jumper should be connected from "8" to "8" if a 4 ohm loudspeaker is used, or from "16" to "16" if an 8 ohm or 16 ohm loudspeaker is used. When using the 16 ohm loudspeaker in this fashion, the amplifier's maximum power output is not as great because of the impedance mismatch, but there is no loss of power when using a 4 ohm or 8 ohm loudspeaker as specified above. The maximum power available into a 16 ohm loudspeaker is still 55 watts, however, and there is a compensating factor. The distortion, as levels below maximum, will be reduced by this type of connection. What happens is that the operating conditions are shifted from maximum power output to minimum distortion. This same operation can also be achieved, of course, by connecting an 8 ohm loudspeaker to paralleled 8 ohm taps, or a 4 ohm loudspeaker to paralleled 4 ohm taps. Note that whenever the two outputs are paralleled, only one input cable should be used, the other input socket should not be used, and the switch is on "mono".

It is also practical to use the "mono" position with a single input source with two separate loudspeakers. In this case, each speaker is connected to one of the screw output strips using the impedance which pertains to the respective speaker. No jumpers are required between the output strips.

A monophonic preamplifier which requires power from the amplifier can be connected to either of the two power takeoff sockets.

ENJOYING STEREOPHONIC SOUND

Stereophonic sound offers an important enhancement of enjoyment of your high fidelity system. The proper setup and use of your stereophonic system will bring considerable satisfaction. However, stereophony introduces problems in high fidelity reproduction which can diminish your enjoyment of your hi fi system unless these problems are understood and corrected. These few notes on the subject should assist materially in the installation and use of a stereophonic system which adds to your listening pleasure.

The pieces of equipment to be used should be as similar as possible in each channel. This is particularly true for the loudspeaker to be used. Different types and brands of speakers have very great differences in frequency response and other important characteristics. If, for example, one speaker has a peak in response at a certain frequency where the other does not, the stereophonic balance will be changed at that frequency. The need for frequent rebalancing is due to this type of dissimilarity.

There has been a relatively high proportion of dissatisfaction with stereo which has arisen because of the attempt to attach an inferior second channel to complete a system. If this channel differs from the first channel it frequently destroys any potential benefits of stereophonic sound.

The proper reproduction of monophonic discs through the stereo system requires the cancellation of identical signals (of opposite phase) so that there is no unwanted vertical signal component in the output. This requires either the paralleling of the two sides of the cartridge or the paralleling of the outputs of identical preamps. If the preamps are slightly different, the vertical components cannot be eliminated properly. In Dynakit preamplifiers, the critical components which determine the response characteristics of the preamplifier playback characteristics have a tolerance of only 1% so that this problem cannot cause difficulty.

Channel phasing is a problem of stereo which is readily solved, once understood. If, on a single sound, one speaker cone moves inward while the other moves out, the system is not properly phased, and the sound area between the speakers will lack homogeneity. All tapes and all discs are now reproduced so that their phasing is consistent. Therefore, once phasing of the playback equipment is set it can be maintained for all tape and disc sources without further change.

To check for proper phasing, play a monophonic recording so that one signal comes through both channels. Then move back and forth between the speakers. If phasing is correct, there will be a

smooth transition of sound between the speakers. If it is not correct, there will be an intermediate area where the sound will shift from one to the other. If phasing is not correct, it can be rectified by interchanging the two leads between one of the amplifier channels and its associated speaker. There should be no need to change phasing once the system is set up properly.

Proper phasing of the stereo pickup or tape head is generally accomplished by the manufacturer of this item. However, this can be inverted in installation if directions are not followed precisely. If there is a drop in volume using a monophonic tape or disc, this indicates probable incorrect phasing. An interchange of ground and "hot" side of one of the cartridge channels or of the two leads to one channel of the tape head will remedy this type of incorrect phasing.

Hum is another problem which the stereo disc playback cartridge can introduce. In some cases (particularly where independent preamps are used for the two channels) the use of a common ground lead on the two inputs will provoke a hum condition. For this reason, many stereo pickup manufacturers provide separate ground connections for each channel by using four cartridge terminals. The cable shields of the two channels should be kept separated.

If a three terminal magnetic cartridge arrangement is used, it is very possible that hum will be encountered if the equipment from the two channels has any additional interchannel connection (beside the common shield from the pickup). Connection of the Stereo 70 should not give this trouble. However, dissimilar units in each channel can be a source of hum when three terminal cartridges are used. Crystal and ceramic cartridges which go into high level inputs should not normally introduce this type of hum problem.

Positioning of loudspeakers will affect the quality of stereophonic reproduction. Generally, moderate distances of six to ten feet along the same wall provide the best effect. If greater spacing is required, the use of a blend control can help to provide "fill" in the middle. However, if extreme distance is required, a "phantom" middle channel is useful. It has generally been established that an L+R combination of the two channels provides the best center fill. Information on the proper method for obtaining this signal, using either the two regular stereo amplifiers, or a third amplifier, may be obtained on request from Dynaco, Inc. This arrangement will also provide a combined signal for a remote monophonic extension speaker.

In most rooms, the proper balance of the stereo system will be different for different listening positions. If the listening positions are rela-

tively far from the speakers, this problem is diminished, and optimum results are obtainable for several listening positions simultaneously.

The most basic consideration of the installation and use of a stereophonic system is that stereo alone does not create realism and high quality sound. Two low grade stereo channels will not give the quality of one high grade monophonic channel. There is no substitute for high quality components, carefully installed.

IN CASE OF TROUBLE

Your Dynakit Stereo 70 has been designed to be as free from trouble as possible. However, a mistake in assembly or a defective component can affect its performance or make it inoperative. Some trouble-shooting procedures are suggested in case difficulty is encountered. Naturally the wiring should be checked very carefully to make sure that all connections have been made in accordance with instructions.

The tubes should light after a few seconds of warmup. If they do not, it is probable that there is no ac voltage getting into the amplifier, which indicates a possible blown fuse.

Fuse failure

If fuses blow frequently without apparent cause, this may sometimes be rectified by using a slow blow type of fuse. However, do not exceed the 3 ampere fuse rating when replacing fuses.

If fuses blow within 30 seconds of turning the amplifier on, remove the GZ-34 rectifier tube and see if this cures the problem. If it does, the rectifier may be bad and another should be tried. A 5U4GB type of rectifier can be substituted for trial purposes, although using this tube type will cut down the maximum power rating of the amplifier. If the GZ-34 is not at fault, the quadruple section filter capacitor may be shorted. Generally, shorts in this section of the amplifier will show up in a measurement of resistance (with the amplifier unplugged from the 117 volt line) from capacitor to ground. This resistance should exceed 100,000 ohms.

Fuses blowing with all tubes removed indicate either miswiring or a defective PA-060 power transformer.

Tubes glowing

If one (or a pair) of the EL-34's glows a bright red color after slight warmup, it is possible that the tube is bad, or there may be a fault in the bias supply which supplies negative voltage to the EL-34's, measurable (with a high impedance meter such as a VTVM) at pin #5 of each EL-34. The

actual value of negative voltage will depend on the setting of the respective bias potentiometer. With the Biaset connection reading the proper 1.56 volts, the negative voltage at the EL-34 tubes should be within 20% of minus 32 volts. If the two tubes in a pair have different negative voltages at pin #5, as measured by a VTVM, this is a clue to a defective component or wiring. (V2 and V3 make one pair; V6 and V7 make the other pair). A small difference in voltage indicates either a runaway tube (which can be checked by borrowing the pair from the other channel) or a leaking .1 mfd capacitor on the PC-3 board. If one tube has no negative voltage, it indicates that there is an open connection from the bias supply to this tube.

If no meter is available, it is possible to pin down the fault with a glowing tube by switching the two tubes of the pair. In the same socket exhibits the glow, the fault is in the amplifier bias supply or components. If the same tube glows in transposed position, it is most likely a defective tube.

The tubes supplied with the Stereo 70 are matched and should be completely interchangeable. When making replacements of tubes, they should preferably (although not absolutely essential) be replaced in pairs which are matched. There is no need to maintain matching of all four EL-34 tubes.

In emergencies, substitution of the tubes can be made with other tube types. The 5881 and KT-66 can be used in place of the EL-34's provided the bias is readjusted to give 1.56 at the Biaset check point. The 5U4G or 5U4GB can be used in place of the GZ-34. There is no substitute for the 7199 tube.

No signal

If there is no signal coming through the amplifier, each side should be checked separately to see whether one channel may be working. If one works, and the other does not, the working channel can be used for test purposes. For example, the tubes can be interchanged to determine whether they will work in either channel. In this way, a defective tube can be singled out.

It is advisable to remove the input cable and see whether insertion of the plug makes a "thump" through the loudspeaker. Sometimes, a defective cable or preamp prevents signal from coming through while the amplifier itself is operative. If there is no signal from the preamplifier, but a "thump" can be induced by unplugging the shielded cable from the preamplifier or by inserting the tip of a small screwdriver into the input socket, then the fault is not in the amplifier but in the associated equipment.

If a meter is available, voltages should be checked in comparison with the voltage table in-

cluded in these instructions. Departures of more than 10% from the values shown indicate possible malfunctioning of some of the circuit components.

Hum and noise

If excessive hum or noise appear, it is necessary to determine whether they occur within the amplifier. Sometimes noise in the preamplifier is blamed on the amplifier. The simple test is to remove the cables from the input socket and see whether the same noise is present. If the noise is removed when the cable is unplugged, it is in the preceding equipment which should then be checked. If not, it is probably in the amplifier.

Compare the noise in the two channels. If both are the same, it is not likely to be tubes like the 7199 or EL-34 which affect only the channel in which they operate, but it could be the GZ-34 or the quad capacitor or bias capacitors which are common to both sides of the circuit.

Sizzling sounds coming through the loudspeaker may come from poor contacts between circuit elements and chassis. Make sure that ground connections are tight.

In some rare cases, loud pops may be heard through the loudspeakers. These can come from poor conditions inside the pins of the EL-34 tubes. Touching a hot soldering iron to these pins will rectify this. Make sure that solder is not deposited on the pin or the tube may not fit the socket.

In the event that trouble shooting will not correct the problem, factory consultation is available without charge, and factory service at moderate charge.

FACTORY SERVICE AND GUARANTEE

The Dynakit Stereo 70 is designed to provide good service over a long period of time. It is intended to be used at the conventional 117 volt line input found in most homes. Operation up to 125 volts will not cause any problem. Above that voltage, it is suggested that a voltage regulating or adjusting device be used in order to protect the components in your amplifier. The normal guarantee on the equipment is not applicable if it is used above the 125 volt rating.

All parts in the Stereo 70 are guaranteed for a period of one year from purchase except tubes which carry the standard EIA guarantee of 90 days. Parts which are defective will be replaced at no charge if they are returned prepaid to the factory either directly or via the dealer from whom the kit is purchased. Many Dynaco dealers carry spare parts in stock to facilitate replacements. After the guarantee period is past, Dynaco will supply any non-standard parts used at net prices. Parts

which are standard dealer items can be purchased from most electronic supply stores.

If transformers are returned for factory repair or exchange, they should be removed from the equipment without cutting the leads short. If leads have been cut rather than unsoldered, so that they are no longer usable, the guarantee on the transformer is voided.

In the event that the assembled kit does not function properly or breaks down after some use, Dyna Company will service the kit for a service fee of \$7.50 plus the cost of parts which have been damaged by the user or are past the guarantee period. This service facility is not available for kits which are incompletely wired, or have been wired with other than rosin core solder, or in which changes or modifications have been made without factory authorization. In addition, NO PARTS WILL BE REPLACED NOR WILL ANY SERVICE BE AVAILABLE FOR KITS WHERE THE GUARANTEE POST CARD HAS NOT BEEN RETURNED. THE SERIAL NUMBER ON THIS INSTRUCTION BOOK MUST BE MENTIONED IN

CORRESPONDENCE, PARTS RETURN, OR KITS RETURNED FOR FACTORY SERVICE. It is the factory prerogative to limit the service facility to one year from date of purchase.

When shipping the amplifier for service, a note must be attached specifying the symptoms, the name and address of the sender, and the serial number of the unit. The kit should be securely packed with stuffing inside the cover to prevent the tubes from falling out of the sockets. It should be placed in a rugged carton surrounded by several inches of shredded paper or other soft packing material. The original carton is not suitable for shipping a wired amplifier.

Shipment should be made by prepaid Railway Express, where possible; and repaired kits will be returned by Railway Express COD for freight and service charges unless these charges have been prepaid. Parcel post is not a safe method for shipment of completed kits and should not be used.

Dyna Company assumes no responsibility or liability for damages or injuries sustained in assembly or operation of the Dynakit.

STEREO 70 PARTS LIST

Parts of similar type which do not change performance may sometimes be included as a matter of expediency. This will account for slight variations in value and appearance.

	Part No.
1 - Chassis	711004
1 - Bottom plate	711005
1 - Cover	711007
1 - Power transformer - PA-060	464006
2 - Output transformer - A-470	454326
1 - Choke - C-354	423354
4 - Output tube - EL-34	517034
1 - Rectifier tube - GZ-34	514034
2 - Driver tube - 7199	517004
7 - Octal socket	398008
1 - Printed circuit assembly - PC-3	557003
1 - Filter capacitor - 525 v.	298906
2 - Capacitor - 50 mfd	284506
1 - Dual disc capacitor 2 x .02 mfd	224403
1 - Selenium rectifier	544042
2 - Four screw terminal strip	374004
1 - Fuse post, rubber washer and mounting nut	341001
1 - Fuse - 3 amp Slo-Blo	342030
1 - Line cord	322092
1 - On-Off switch - SPST	331101
1 - Input switch - SPDT	332202
1 - Input socket insulator	875002
1 - Dual input socket	355002
2 - Potentiometer - 10,000 ohm	145103
1 - Seven lug terminal strip	377207
1 - Hookup wire	

RESISTORS

	Part No.
2 - 15.6 ohm	120150
4 - 1,000 ohm (brown-black-red)	111102
2 - 10,000 ohm (brown-black-orange)	115103
2 - 470,000 ohm (yellow-violet-yellow)	111474
2 - 10 ohm (brown-black-black)	111100
1 - 6,800 ohm (blue-grey-red)	114682
1 - 22,000 ohm (red-red-orange)	114223

HARDWARE

	Part No.
4 - Rubber foot	859002
33 - Screw - #4-40 x 1/4"	611245
31 - Nut, #4-40	614245
30 - Lockwasher, #4	617205
1 - Screw, #4-40 x 3/4"	611205
4 - Sheet metal screw, #6	612365
10 - Screw, #8-32	611465
14 - Nut, #8-32	614465
14 - Lockwasher, #8	617405
1 - Rubber grommet	895003
2 - Solder lug	639308
2 - Lockwasher, 3/8"	617065
2 - Nut, 3/8"	614065
2 - Cable clamp	713001

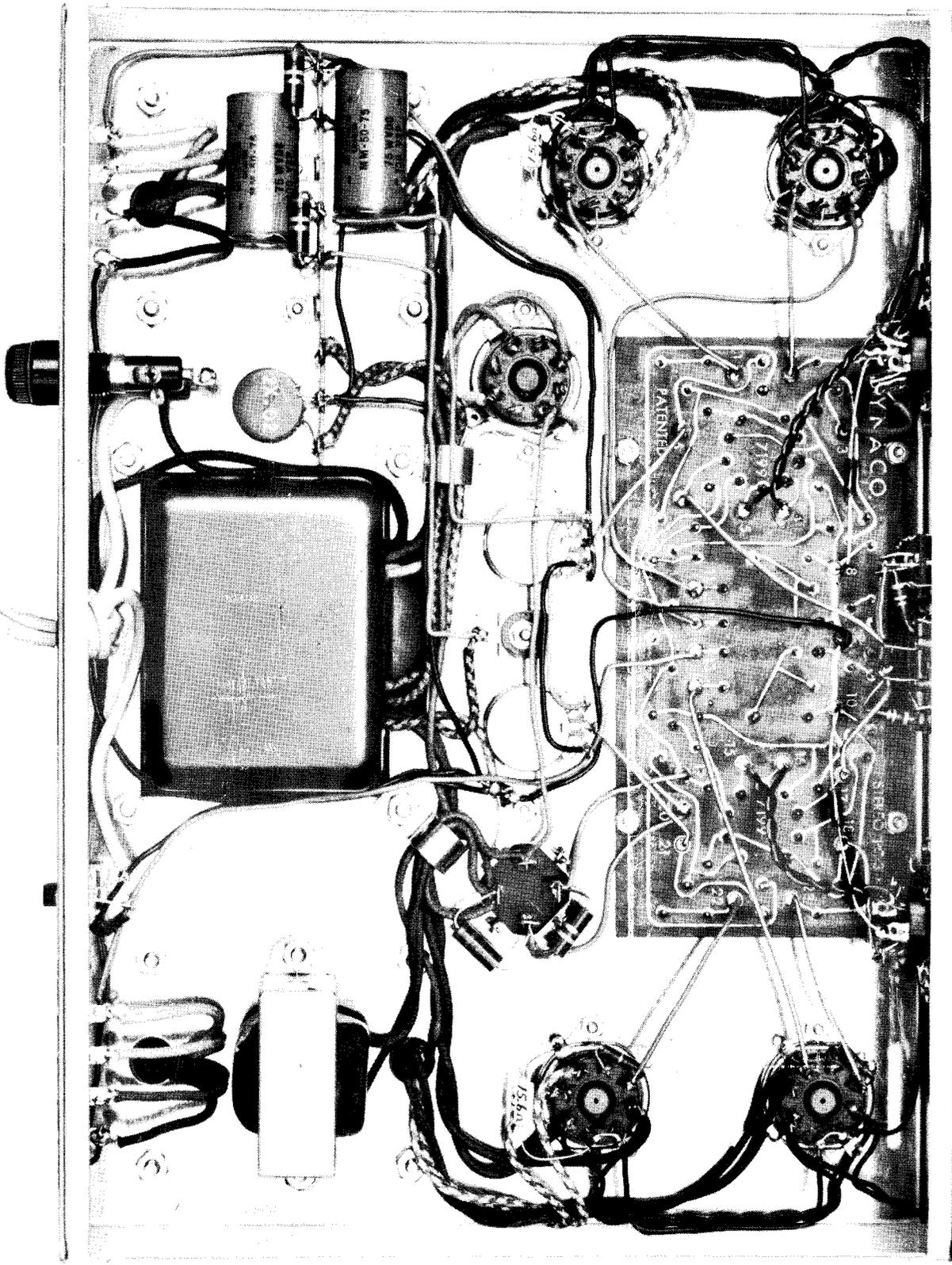

FRONT
PANEL

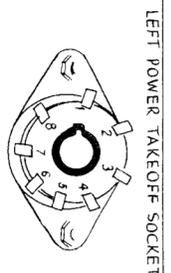

LEFT POWER TAKEOFF SOCKET

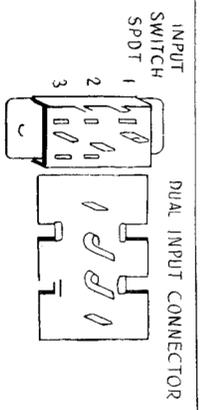

DUAL INPUT CONNECTOR

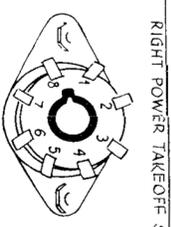

RIGHT POWER TAKEOFF SOCKET

NOTE
DIRECTION
OF KEYS



CUTOUT FOR PRINTED CIRCUIT BOARD

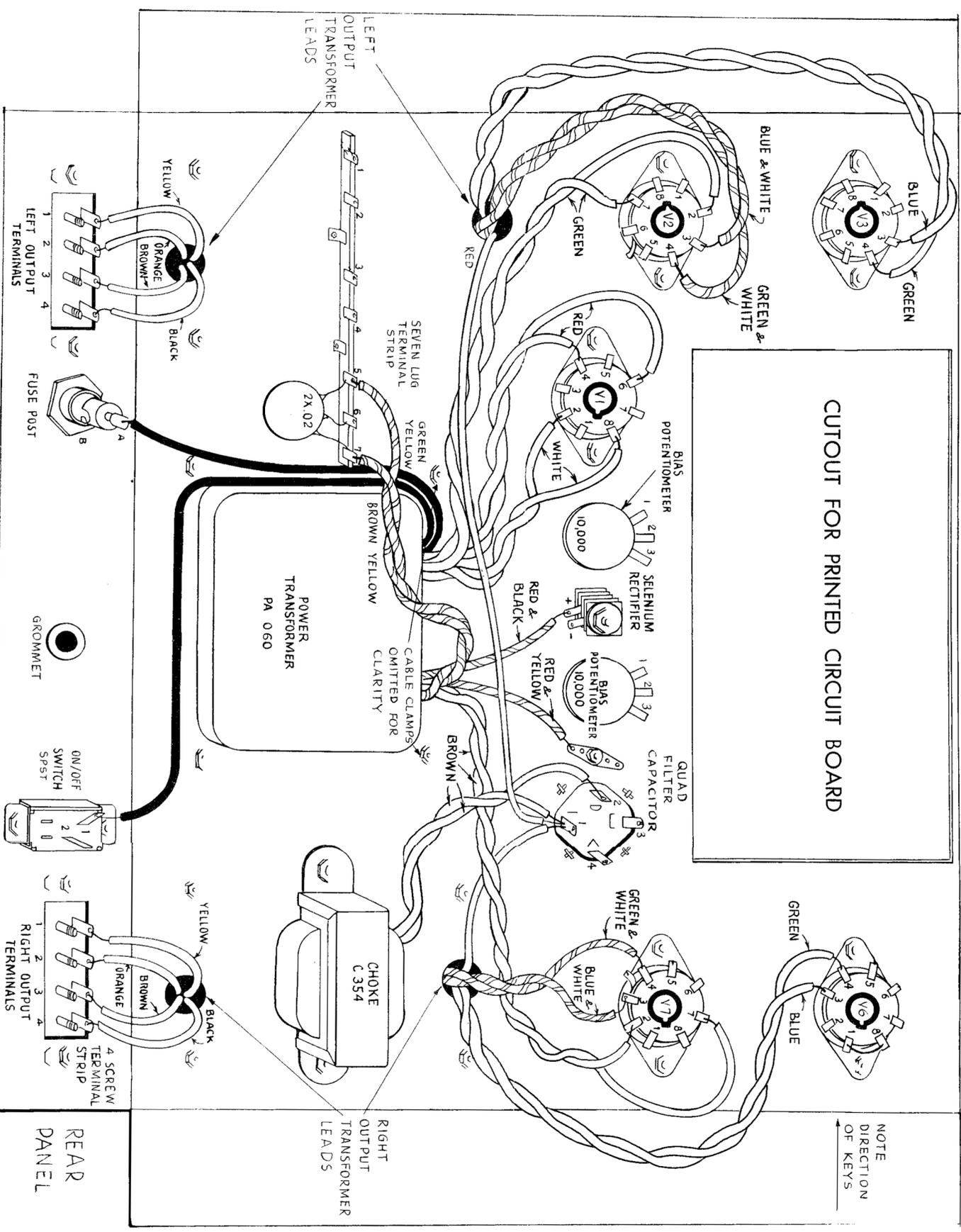

LEFT
OUTPUT
TRANSFORMER
LEADS

RIGHT
OUTPUT
TRANSFORMER
LEADS

POWER
TRANSFORMER
PA 060

CABLE CLAMPS
OMITTED FOR
CLARITY

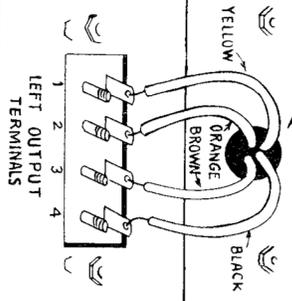

LEFT OUTPUT
TERMINALS

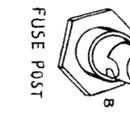

FUSE POST



GROMMET

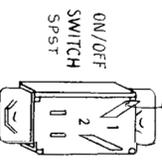

ON/OFF
SWITCH
SPST

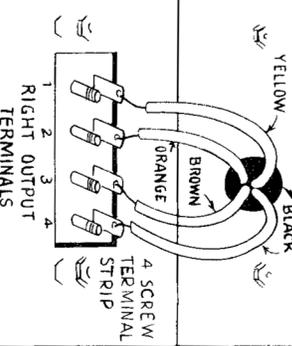

RIGHT OUTPUT
TERMINALS

REAR
PANEL

LEFT POWER
TAKE OFF SOCKET

RIGHT POWER
TAKE OFF SOCKET

FRONT
PANEL

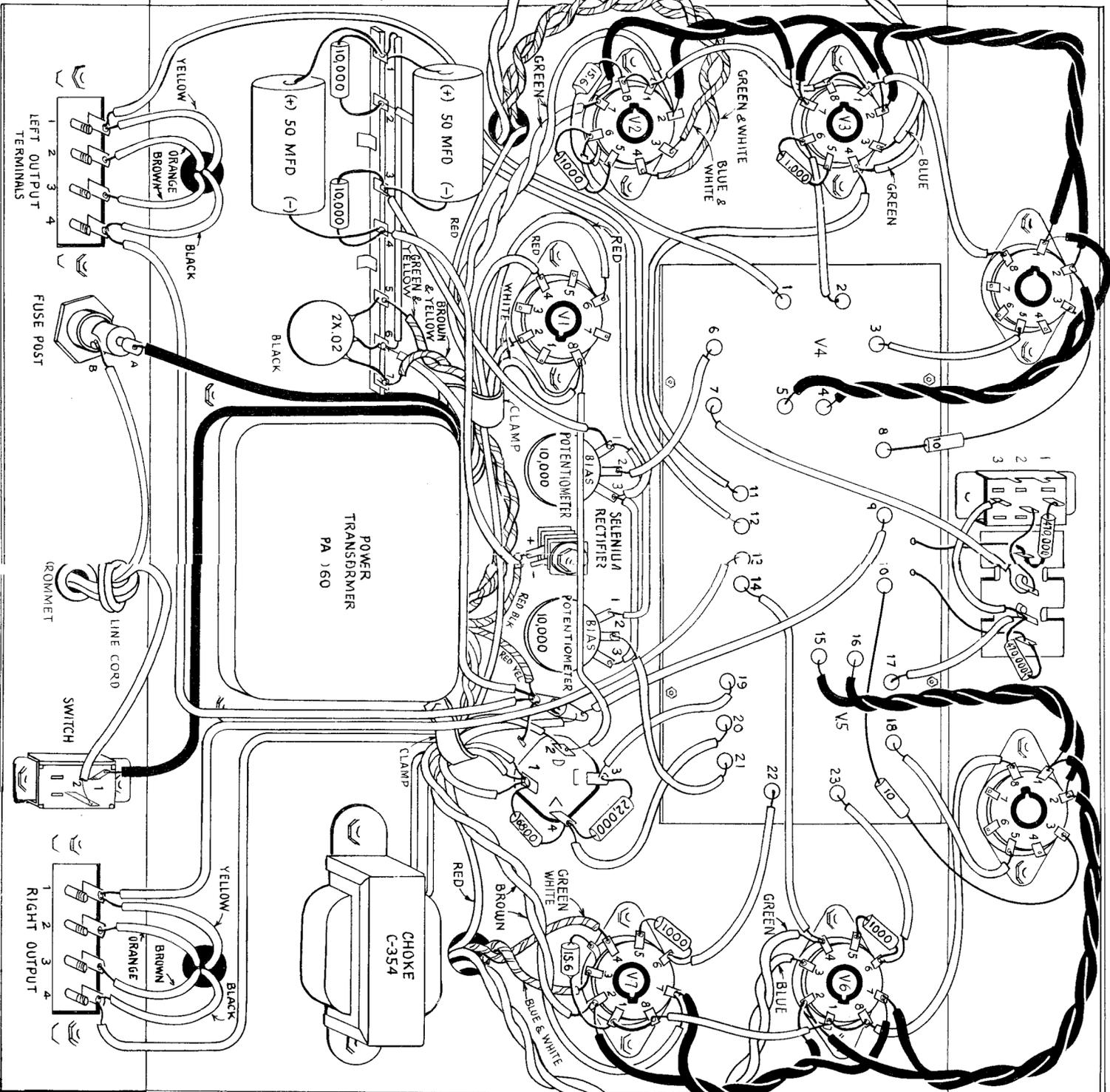

7 LUG
TERMINAL
STRIP

LEFT OUTPUT
TERMINALS

FUSE POST

LINE CORD
SWITCH

RIGHT OUTPUT
TERMINALS

REAR
PANEL