

dynaco

TUNER FM-1

SERIAL NUMBER

This number must be mentioned in all communications concerning this equipment.

INSTRUCTIONS FOR

ASSEMBLY ALIGNMENT OPERATION



Price \$1.00

dynaco inc. 3060 Jefferson St., Philadelphia, Pa. 19121 U.S.A.

Bob01605@aol.com

SPECIFICATIONS

BASED ON IHFM STANDARD T-100

Useable Sensitivity:	4 microvolts for total noise and distortion 30 db below 100% modulation
Signal-to-Noise Ratio:	70 db below 100% modulation level
Harmonic Distortion:	less than 0.25% @ 100% modulation
Drift:	less than 0.03%
Frequency Response:	± 0.25 db 20 cps to 20 KC ± 0.5 db 10 cps to 40 KC
Capture Ratio:	5 db
Selectivity:	54 db
Audio Hum:	73 db below 1 volt output
AM Suppression:	greater than 63 db

ADDITIONAL SPECIFICATIONS

IM Distortion:	less than 0.5% from 10 microvolts to 100,000 microvolts @ 100% modulation
Audio Output:	2 volts @ 100% modulation
Output Impedance:	less than 5000 ohms
Discriminator Peak to Peak Separation:	greater than 900 KC
Antenna Input:	300 Ω balanced 75 Ω unbalanced
Dial Calibration Accuracy:	0.2%
Power Consumption:	50 watts

DYNATUNER FM-1

DESCRIPTION

In selecting the Dynatuner for your FM receiver you have chosen one of the most intensively engineered high fidelity components on the market today.

The Dynatuner is a fresh engineering concept, not an adaptation of an existing production design. To produce a tuner having optimum performance, every portion of the circuit has been carefully investigated in terms both of performance maxima and of the overall stability of operation and simplicity of adjustment required of a kit design.

The result of this effort is a tuner which provides the same top performance in your home as it does in the laboratory. Without any test equipment—just following the simple adjustment procedures in this manual—the kit builder will achieve the high performance normally obtainable only with laboratory test and alignment equipment.

There is no longer any question whether adjustments have shifted during shipping and handling as frequently happens with FM tuners. In the Dynatuner all adjustments can be easily checked; and, of course, the periodic maintenance required of all tuners is simply and easily made without a trip to the serviceman. This adjusting technique has been obtained without any sacrifice in tuner performance. In fact, the converse is true. The care and control necessary to make these adjustments absolutely reproducible has resulted in a significantly higher level of performance combined with the required stability.

In addition to the adjustment requirements, the basic engineering objective was to produce a tuner design of adequate sensitivity for fringe area reception, with distortion levels of the recovered audio signal comparable to that measured on the best of audio amplifiers.

The significant advantages of etched circuit construction in terms of reliability, reproducibility and durability are amply demonstrated in the Dynatuner. Their use has further accomplished the ultimate goal of improved performance. In no other tuner—kit or factory wired—has exact component placement and lead layout been so accurately defined. The excellent specifications of the Dynatuner are possible, and guaranteeable, unit to unit, lab model to production kit, because of the extraordinary uniformity which etched circuits provide, and the inherent stability of the circuit configuration.

There has been no intent to enter the sensitivity specification race (claims often engineered by the advertising department). However, using the sensitivity standards proposed by the Institute of High Fidelity Manufacturers, this tuner belongs in the highly sensitive class and, in fact, will provide listenable reception of more stations than tuners of ostensibly higher sensitivity rating.

The concentration of effort to reduce distortion has also produced a tuner which is unquestionably the lowest distortion receiver on the market today.

There are many parameters in addition to sensitivity and distortion which are part of a completely satisfactory tuner design. Some are measurable; some are intangible. Extensive field testing under adverse and marginal conditions has proven the Dynatuner to be as fine a tuner as can be obtained today regardless of price or specification claims.

The circuit consists of:

1. Cathode coupled tuned R.F. amplifier stage using a 6AQ8/ECC85 high conductance dual high frequency triode.
2. Screen coupled oscillator-mixer stage using a 6AT8A high conversion triode-pentode.
3. Four I.F. amplifier stages with progressive limiting using two 6BA6 and two 6AU6 tubes.
4. Balanced wide band discriminator with matched semi-conductor diodes.
5. Cathode follower providing detector isolation to the de-emphasis network and multiplex take-off using one half of a 12AX7/ECC83.
6. Plate follower wide band feedback audio output stage using the other half of the 12AX7/ECC83.
7. Tuning indicator 6FG6/EM84.
8. Power supply and rectifier 6V4/EZ80.

The Antenna Circuit

Provision is made to match either a 75 ohm unbalanced or a 300 ohm balanced transmission line thus accommodating any standard antenna array used for FM reception.

The R.F. Stage

The cathode coupled dual triode R.F. amplifier circuit was chosen for the input stage. It combines the high gain and low noise figures of the commonly used grounded grid input with a tuneable input—a necessary feature to prevent overloading from strong local signals when tuning weak signals.

Other more complex circuits have slightly better *theoretical* noise thresholds. However, galactic noise levels at 100 megacycles are of sufficient magnitude to prevent complete utilization of this theoretical difference and the less complex cathode coupled stage closely approaches optimum field results.

The Oscillator-Mixer

The triode section of the 6AT8A is used in a "tickler feedback" tuned grid oscillator circuit. Careful temperature stabilization and choice of operating parameters result in an oscillator circuit with sufficient stability to obviate any need for automatic frequency control with its inherent degradation of the audio signal.

The pentode section of the 6AT8A is used as the mixer. The tube is self-biased for maximum conversion efficiency. The oscillator is injected into the screen circuit to provide complete isolation of the oscillator tuning circuit from the signal tuning circuit at the mixer grid. Oscillator drag (change in oscillator frequency as the mixer tuning is adjusted) is nonexistent, greatly simplifying the adjustment and tracking of the front end. This isolation also reduces re-radiation of the oscillator energy into the antenna which might cause interference in other nearby receivers and television sets.

Circuit constants of the oscillator and mixer circuits have been adjusted to give uniform sensitivity over the entire FM band.

The I.F. Amplifiers and Limiters

Phase shift in an FM signal corresponds to amplitude non-linearity or distortion in an AM signal or in an audio amplifier. Accordingly, the I.F. amplifier circuits were designed for minimum phase shift across the pass band. Since this occurs with undercoupled transformers, the alignment of the I.F. section is greatly simplified. Simple peak tuning (tuning for maximum signal) is the optimum adjustment for the undercoupled I.F. transformers. This minimum phase shift approach maintains low distortion of the audio signal all the way down into the noise and permits useful reception of weak signals even without full limiting action.

A 6BA6 variable-mu pentode is used for the first and second I.F. stages, and 6AU6 sharp-cutoff pentodes are used for the succeeding two stages. Each I.F. stage acts as a limiter when the signal input to that stage reaches a pre-determined point. Thus no automatic volume control circuit is needed and no additional recovery time constants exist to introduce delay on fading signals. There is sufficient gain in the receiver so that the last limiter is effective on input noise.

The Discriminator

A balanced-bridge discriminator configuration is used in place of the conventional unbalanced circuit. This circuit balances out any noise and signal rectification occurring in the plate circuit of the last limiter tube and is the key to the phenomenally low distortion figures achieved by the Dynatuner. A wide band discriminator transformer is used to obtain the full benefit of this design, and matched semiconductor diodes are used in place of vacuum tubes to avoid heater hum at this critical point in the circuit.

The balancing action of this circuit reduces the inter-channel noise (between stations) by a factor as great as 10 db in level over many conventional tuners which use limiter-discriminator circuits.

The Audio Section

The first section of the 12AX7 dual triode is used as a direct-coupled cathode follower between the discriminator and the de-emphasis network. This prevents loading of the high impedance discriminator circuit by the de-emphasis network with its consequent reduction of high frequency transient (square wave) response. A low impedance de-emphasis network is used to feed the volume control of the tuner directly. Also a multiplex take-off point is provided at low impedance which will not affect the regular operation of the tuner.

The second section of the 12AX7 is a feedback "plate follower" audio amplifier compensated for the very wide-band response inherent in the rest of the tuner circuitry.

The Tuning Eye

In operation this eye acts as an indicator showing when a station is tuned properly, and is connected through the appropriate network to the last limiter grid circuit. During a portion of the alignment procedure, the eye is connected to other specified parts of the circuit to indicate correct

alignment. This is the only instrument required during the alignment procedure. The operating point of the eye has been set for extremely precise indication of the optimum tuning (or alignment) condition, and is a more accurate indicator than tuning meters.

The action of the eye in tuning is very sensitive. It will indicate a signal as low as 1 microvolt; it approaches maximum closure at 10 microvolts—yet it cannot be overlapped at higher signal strengths. The center of channel is always indicated precisely. There is no "flat spot" in tuning.

The Power Supply

The power supply is a conventional full wave "pi" rectifier using a 6V4/EZ80 rectifier. Additional power handling capability is included to power a Dynaco multiplex adapter in the space provided on the chassis.

The Dynatuner is engineered to provide the finest available overall performance. It is also designed to maintain this performance level for many years. Unlike other tuners which must be factory aligned to give rated performance, the Dynatuner can be adjusted to, and kept at optimum performance by its owner.

USING YOUR DYNATUNER

Your Dynatuner has been designed to give you the highest quality of FM reception combined with permanence of its excellent operating characteristics. A few moments learning how to use it will amply repay you with increased satisfaction.

The tuner must be connected to either a preamplifier or directly to an amplifier using shielded cable of the type supplied. It is acceptable to use cable lengths up to 25 feet if the tuner is required to be located away from the associated equipment.

The audio cable can be plugged into either of the two output sockets as normally wired. The second socket can be used to connect to the other channel of a stereophonic system or to a tape recorder, or it can be left unused. Later, if you wish to add a Dynaco multiplex adapter, the extra socket will be the output for the second stereo channel by connecting it internally to the adapter, for which space has been left on the chassis. The extra socket can also be connected to the multiplex output of the tuner for use with external adapters. See the Appendix for specific information on this.

The front panel controls of the Dynatuner have been made as simple to use as possible. The function of the on-off switch is obvious. This switch also controls the AC outlet on the rear of the tuner so that it is possible, if desired, to turn both tuner and amplifier, for example, on and off simultaneously. It is also possible when using the Dynatuner with equipment which has additional switching facility, such as the Dyna PAS-2, to leave the on-off switch "on" and use the auxiliary equipment for all the switching.

The tuning knob of the Dynatuner enables tuning from one end of the FM band to the other. By observing the tuning eye, it is simple to see *precisely* when a station is in

tune. The eye reaches maximum closure when the tuning is correct, and the accuracy of tuning is greatest when watching the eye, rather than trying to set to a given frequency as indicated on the tuning dial.

The volume control of the Dynatuner has two possible functions. If the tuner is used with a basic power amplifier, then this operates as a conventional volume control. When used with equipment which has a central volume control, such as a Dyna preamplifier, the Dynatuner volume control is used merely to set the output of the tuner to correspond with the output of other program sources so that there is no need to re-adjust the volume when switching from one program source to another. Normally in this usage, the Dynatuner's volume control will be operated almost fully clockwise, depending on the signal level of other equipment.

All tuners using vacuum tubes generate heat. In the Dynatuner the component parts have been selected with this in mind. Because the tuner has been designed with the cover as an integral part, the unit in effect creates its own thermal environment, and adequate allowance has been made in the design for this normal temperature rise. The Dynatuner should not be used in a confined space. It should be remembered that the heat generated is equivalent to a 50 watt light bulb, and adequate ventilation must be allowed above it. When used with the Dyna PAS-2, for example, the Dynatuner may be placed on top of the PAS-2, but not below it.

For most metropolitan area use, a very small, simple antenna such as a four foot piece of wire secured to either of the screws marked 300Ω , is adequate with the Dynatuner. However, twin-lead wire is included in this kit to provide a folded dipole antenna quite suitable for most indoor use. Instructions for this are given in the Appendix.

In extremely difficult reception areas, it is sometimes necessary to use a coaxial cable for the antenna lead-in connection. The Dynatuner has provision for using this type of lead-in by connecting to the center and one outer screw on the antenna input (marked 75Ω on the bottom plate).

For reception in fringe areas, high gain antenna arrays are frequently required, and your dealer can advise you on the use of these with your Dynatuner. The extreme sensitivity of your Dynatuner, coupled with its excellent limiting action on very weak signals, may well enable you to listen to stations you have not received before, when this tuner is coupled with a properly designed antenna.

GENERAL WIRING PRACTICE

Assembly of the Dynatuner is quite simple compared to general kit assembly requirements. Parts are out in the open in a free and uncluttered layout so there is easy accessibility for wiring or troubleshooting purposes. Construction and alignment of your Dynatuner should not take more than eight hours because of these simplifications.

Upon opening your kit, check the components with the parts list. Familiarize yourself with the components; they can be identified by comparison with the pictorial diagram, by specified color coding, and by pictorial detail.

Tools required for easy assembly of your Dynatuner are a soldering iron (small tip) or soldering gun, long nose pliers, screwdriver, and wire cutters. Although not essential,

a low-cost wire stripper and cutter of the type which can be purchased for less than a dollar will greatly facilitate cutting and stripping the various wires in the kit. A special alignment tool is provided with the kit.

Good soldering technique is essential to satisfactory results from any electronic equipment. **ALL SOLDERING MUST BE DONE WITH ROSIN CORE SOLDER.** There is no warranty on any equipment in which acid core solder has been used. Make sure that the solder is plainly marked "Rosin Core." If you have solder on hand the origin of which is doubtful, it is wise to obtain new 50/50 or 60/40 rosin core solder. Whenever soldering is required from point to point, the assembly instructions specify it by "(S)." If this symbol is not shown after a connection is specified, it indicates that further connections will be made at that point before soldering.

Soldering is accomplished by heating the joint with the iron until solder is hot enough to flow when touched to the joint. It is not desirable to feed the solder to the iron. Solder should be fed to the junction of iron and heated joint. After the solder flows, the iron should be held in place for a few seconds and removed when it is seen that the solder has contacted both parts of the connection—The lug and the wire connected to it. It should not show a ball of solder, but a smooth transition from solder to component lead.

When soldering a part to the etched circuit board, the solder must completely surround the wire lead where it comes through the board. Do not apply excessive solder, but do not hesitate to apply sufficient heat to assure a smooth flow of solder all around the lead and onto the board.

In the case of point to point wiring, before applying solder the joint should be clean and the lead should be crimped in place for mechanical strength. It is not necessary or desirable to wrap leads around contacts many times. A single turn and pinching together with pliers is suitable. After soldering there should be no play at the joint if the lead is wiggled with a pair of pliers. All soldering can be done with a pencil type iron with a low wattage rating. A small tip is extremely useful when working in confined space. If a soldering gun is employed, it should be used with discretion since the amount of heat available is far more than required for soldering light wires. You should also be careful not to use excessive solder. The smallest quantity of solder that makes a smooth contact between the parts being soldered is best.

Component leads should be trimmed as they are used; the length should be such that the proper connection can be made from point to point without strain on lugs or components. Most capacitors and coils used on the printed circuit boards have pre-cut leads. The leads of the resistors for the boards should be cut as described later. Care should be exercised not to allow wires to touch one another unless they are actually connected to the same point.

The instructions which follow have been arranged for simplified procedure in which the work can be done without interference between the various portions of the wiring. It is recommended that the instructions be followed on a step by step basis, checking off each step as it is completed. The pictorial diagrams should be used for reference and all connections checked against these before going on to the next step. If the wiring is done methodically and each step checked carefully, your tuner should work without difficulty as soon as it is completed.

ASSEMBLY INSTRUCTIONS

You will first assemble the two etched circuit boards PC-7 and PC-8, and then mount these and the other components on the chassis and complete the wiring. The Dynatuner's use of etched circuit boards, onto which most of the parts are mounted, greatly simplifies your assembly of the kit, and contributes strongly to its outstanding performance. Close attention to the suggestions made here will enable you to realize its fullest capabilities.

Before starting assembly of the etched circuit boards, observe detail A. A GOOD SOLDERING JOB IS ESSENTIAL TO THE PERFORMANCE OF YOUR TUNER. Soldering to etched circuit boards is no more difficult (and in some ways much easier) than conventional point-to-point wiring. If any difficulty is experienced in attempting to solder to the copper sheet which is bonded to the board, light rubbing with an ink eraser can clean the copper to simplify the process.

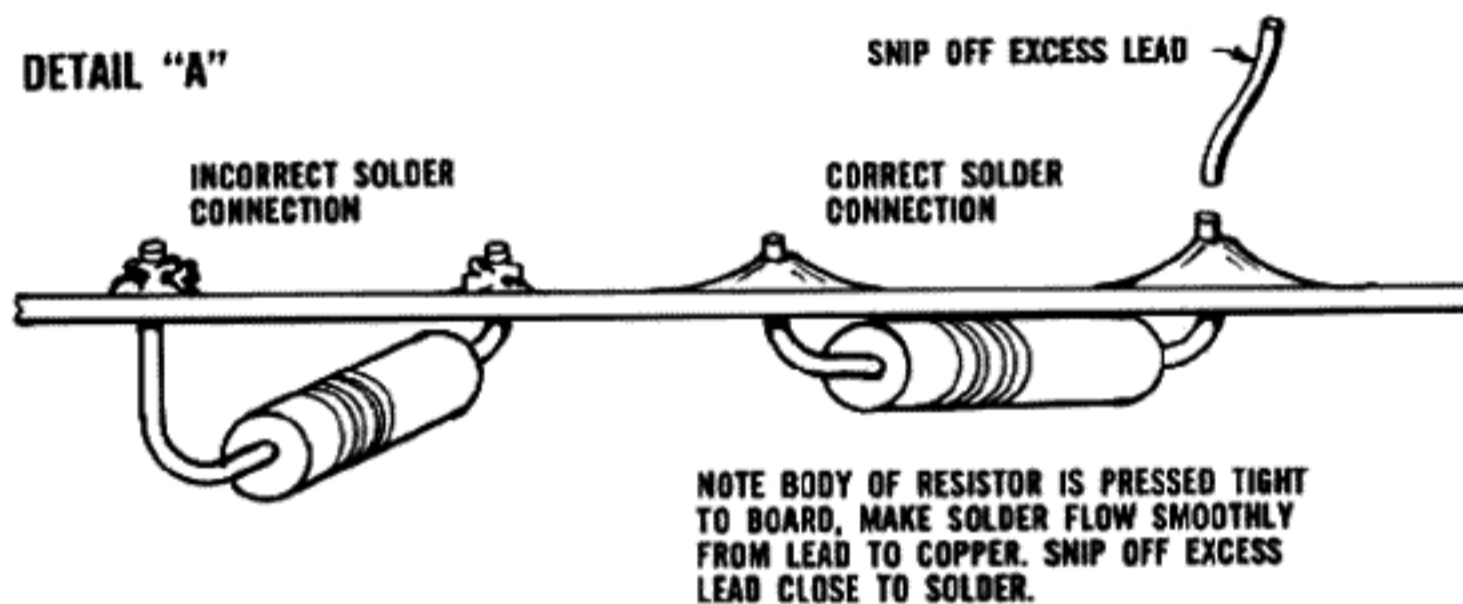

Be sure enough heat reaches both the copper on the board and the wire to be soldered to make a smooth solder junction. When making connections to the eyelets, be sure that the solder flows from the wire to the eyelet to the board, so that the eyelet is soldered to the wire and to the board at the same time. When installing components, be careful not to cover up the identifying numbers. Avoid getting solder on the outer $\frac{3}{8}$ " edge of the boards. This area contacts the chassis when the boards are mounted and solder splashes here will prevent a uniform contact.

You will note that on each etched circuit board all of the component positions are diagrammed on the top of the board (the side without the copper). The identification symbol for each component is marked between the holes into which its leads will be inserted. Resistors may be identified by comparing them with the color code provided on the parts list. Each disc capacitor is marked with its value and any special characteristics. Other special components will be identified as they are called for in the assembly process.

Assembly of the R.F. circuit board PC-7

- 1() Position the PC-7 etched circuit board in front of you according to the pictorial diagram. Support the board over an open box or between two objects so that the leads from the components may project through. Insert all of the one-half watt resistors in their places on the circuit board. To bend the leads of each resistor to the correct shape, hold it between the thumb and forefinger of one hand and bring the thumb and forefinger of the other hand just across the ends of the body, bending the leads as you do so. See detail B. It will help in rechecking your work to orient the color codes of all resistors uniformly.

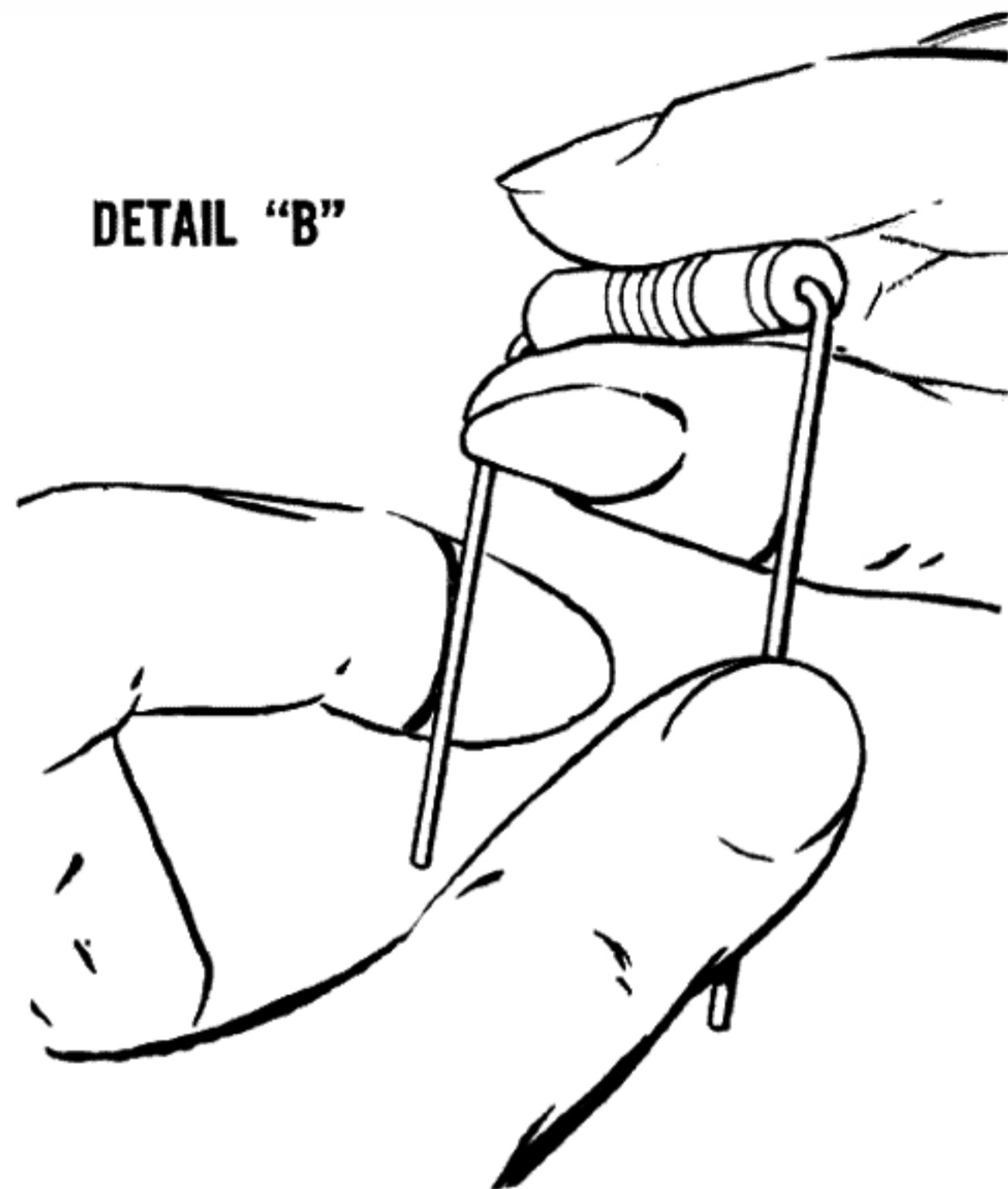

When all of the one-half watt resistors are in place, put the chassis bottom plate over them to hold them in position and carefully turn the board and bottom plate upside-down. Solder each lead with a small amount of solder. The solder should flow smoothly all around the lead onto the copper. Cut off all excess leads. See detail A.

After soldering, there should be no space between the bodies of the resistors and the top of the PC board. If there is, the resistor should be gently pressed to the board while the soldered leads are reheated, until the resistor is flush with the board.

- 2() Support the board as in step 1. Insert the 3.9 microhenry choke L2 and the heater choke L5. Insert all the one watt resistors. Insert the 2.2 mmfd tubular capacitor C11 (red, red, white and gray dots). Invert the board and solder each lead of these components and trim off the excess.
- 3() Insert the two nine pin sockets. Note the location of the flat side of each socket. Be certain that each tab goes into its hole and does not bend over on top of the board. Seat each socket firmly to the board and then solder each pin and the center ground pin.
- 4() Referring to the pictorial diagram and the values marked on the individual capacitors, insert all the

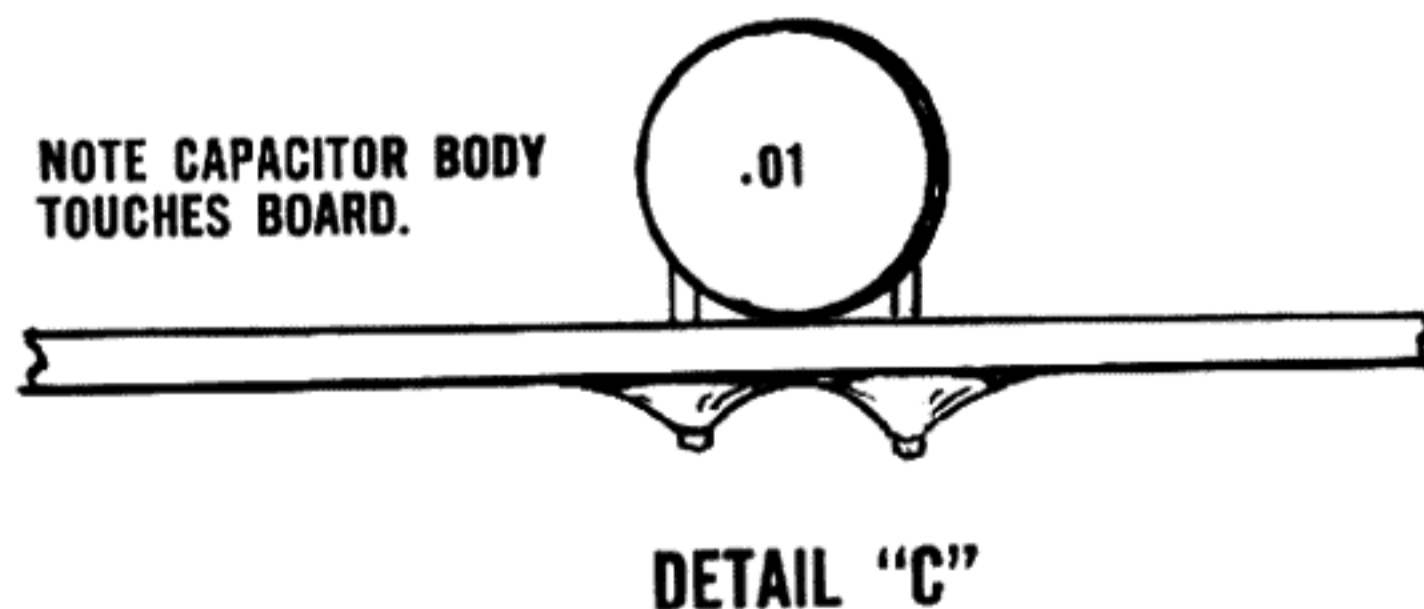

disc capacitors as shown in detail C. Make certain that the body of the capacitor touches the board. The leads of the disc capacitors may be bent slightly to prevent them from falling out when the board is turned over for soldering. Be careful not to allow the lead to form a "bridge" to another portion of the circuit. Solder each capacitor lead.

- 5() Mount the oscillator coil L4 (the one with four leads at the bottom) in the group of four holes indicated. The two heavier leads are inserted in eyelets #10 and #11. Mount the mixer coil L3 (the one with only two leads at the bottom and none at the top) at eyelets #7 and #8. Be sure it is oriented as shown on the pictorial diagram. Make sure each coil form is seated firmly to the board and solder all of the coil leads.

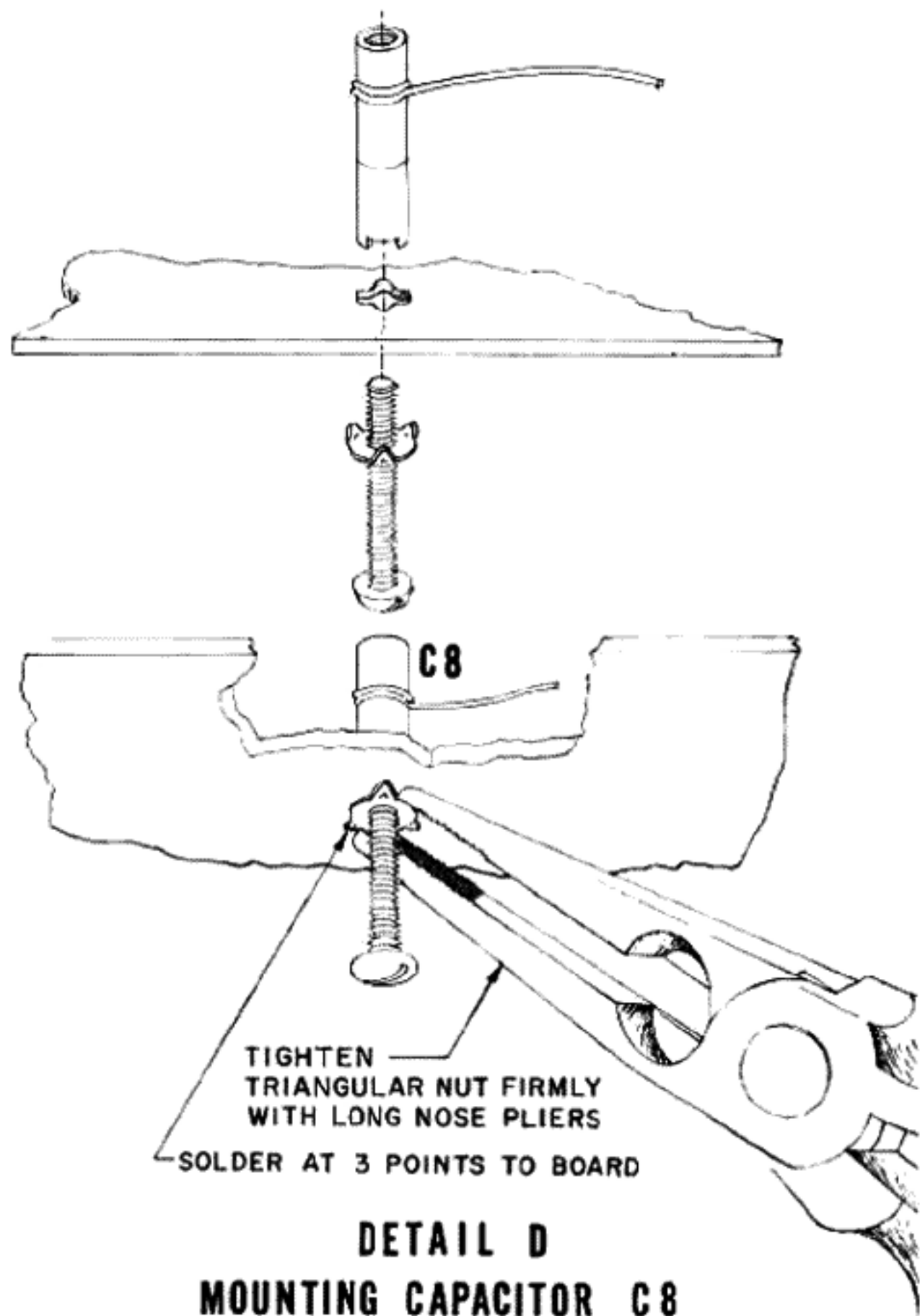

- 6() The oscillator trimmer capacitor C8 is a white tubular ceramic form with a #6 screw and triangular nut. The nut is supplied threaded onto the 3/4" screw in the hardware bag. Be sure that the points of the nut face away from the screw head, and run the nut out on the screw so that it is 1/2" from the head. Insert the tabs of the capacitor into the matching cutout on the board. Note the location of the wire lead. Hold the capacitor firmly against the board, and turn the screw in from the bottom (see detail D) until the triangular nut is firmly seated. Now tighten the nut with long nose pliers, while pressing the capacitor to the board. The points of the nut must dig into the copper so that the capacitor mounting is absolutely rigid. Solder the nut to the board at

the 3 points. Insert the top lead of the capacitor into the hole indicated in the pictorial, keeping it as short as possible, and solder the lead.

- 7() Mount the special temperature compensating capacitor C7 (2.55 mmfd N2200, with six color stripes) as shown in the pictorial. Make sure it is seated snugly against the board and against the tube socket. Solder both leads.
- 8() Mount the I.F. transformer T1 (one of the four marked 432001) on the board. Note the slot in one corner of the top of the can. Be sure to mount the transformer with this slot oriented as indicated in the pictorial. The transformer should snap into place and seat firmly against the board. Solder the mounting tab next to C12 first, but do not solder the other mounting tab. Solder each connecting lug. Avoid excessive heat, but be sure a good connection is made.
- 9() Insert the ground straps into their slots in each of the tube sockets. Observe the direction of the offset in these ground straps as shown in the pictorial diagram. Solder both to the board.
- 10() Insert a round toothpick or similar instrument into eyelets #2 and #4 from the bottom of the board. The purpose of this is to prevent solder from filling these eyelets. Now solder the eyelets to the copper on the board and remove the toothpick. Insert the two heavy leads of the antenna coil L1 into eyelets #2 and #4. Note that this coil is mounted on the *bottom* of the board, and is oriented to align the center slug with the hole in the board. Solder the two leads to the eyelets on the *top* of the board. It may be necessary to scrape the coil leads, or to ream the eyelet(s) slightly if the inside of the eyelet is not perfectly free of solder, as this is a very snug fit.
- 11() Strip a 1" piece of wire bare. Solder one end of it to eyelet #3 on the bottom of the board.

Assembly of the I.F. Circuit Board PC-8

- 1() As before, support the board on an open box or between two objects so that the leads will have clearance below the board as you insert components. Insert all of the one-half watt resistors, after bending their leads as before. Using the bottom plate, turn the board over and solder all of the leads. Cut off the excess leads. Be sure all the resistors are seated firmly against the board.
- 2() Insert the one watt and the two watt resistors and the four heater chokes L6, L7, L8 and L9. Solder these components in place and trim off the excess leads on completion.
- 3() Mount the four seven pin sockets, being careful to see that none of the tabs are bent over on top of the board. Position them as shown in the pictorial. Mount the one nine pin socket, as shown. It is necessary to first snip off one of the molded tabs on the side of this socket in order to clear the adjacent resistor. This is easily done with a pair of pliers. Make sure that each socket is seated firmly against the board and then solder all of the pins *and* all of the center ground pins.

- 4() Insert all of the disc capacitors. As before, the leads of these capacitors may be bent slightly to hold them in place, but be careful that no "bridges" are formed to adjacent parts of the circuit. Solder all of these capacitors.
- 5() Install the mylar capacitor C29 near the V7 socket. Solder both leads and cut off the excess.
- 6() Insert the vertically mounted .22 mfd 200 volt tubular capacitor C31 in its two eyelets. Solder both eyelets.
- 7() Insert the remaining IF transformers T2, T3 and T4 (all 432001). Follow the location of the slot at the top of each transformer as shown in the pictorial. Solder all mounting tabs and all lugs. Avoid excessive solder, which may flow into the transformer and damage it. Make sure the chokes L6 and L8 do not touch the transformers. The discriminator transformer T5 will be mounted later.
- 8() Insert ground straps in each of the sockets. Note the orientation of the offset. Solder these ground straps.
- 9() Install the pilot light socket in the holes indicated. Observe that the connecting tab from the socket center contact goes into the hole adjoining eyelet #20. *Do not install it backwards!* Solder both tabs.

Chassis Assembly

- 1() Hold the PC-7 board as shown in the pictorial, with the I.F. transformer away from you, and carefully pick up the tuning capacitor C1, holding it so that the shaft points away from you. Be particularly careful that you do not touch the semicircular copper and aluminum colored plates of the capacitor. If these are bent, even slightly, it will be difficult to get the tuner to track accurately across the dial when you come to the alignment procedure. Now insert the small tabs which protrude from the bottom of C1 into the corresponding five holes in the top of PC-7. *Be careful capacitor C7 is not damaged.* This fit is especially snug, but be sure that the capacitor is fully seated against the board. The two threaded studs of the capacitor will also engage the board.
- 2() Mount the PC-7—C1 assembly on the *top* of the chassis, locating it by the four threaded studs of C1. Install four sets of #6 (medium size) lockwashers and nuts on these studs but do not tighten them.
- 3() Fasten the PC-7 board in place with five sets of #4 (smallest size nickel plated) hardware. Install the screws from the top, and secure with a lockwasher under each nut. Tighten these, and also tighten the nuts on the capacitor studs.
- 4() Mount the tuning capacitor shield can, using three sets of #4 hardware. Make sure the shield lies between socket V2 and capacitor C6. The tab of the shield is fed through the hole in PC-7 for the mounting tab of T1. Solder both of these tabs to the board.
- 5() Mount the I.F. circuit board PC-8 on the *top* of the chassis. Note that the mounting holes in the board are not evenly spaced and the board can only be mounted in one position. Fasten with eight sets of #4 hardware.
- 6() Mount the quadruple section electrolytic capacitor C32 in the center of the chassis. Note the

identifying marks at each lug of the capacitor (semi-circle, square, triangle, and blank) and orient the capacitor according to the pictorial diagram. Fasten it rigidly in position by twisting the four mounting lugs $\frac{1}{4}$ turn with a pair of pliers.

- 7() Mount the on-off switch on the front of the chassis. Use two #4 screws. Lockwashers and nuts are not necessary as the holes in the switch are threaded. Follow the position of the switch lugs shown in the pictorial.
- 8() Mount the three screw terminal strip with two sets of #4 hardware. Note that the terminal strip is mounted on the *outside* of the rear flange of the chassis. Refer to the pictorial for proper orientation.
- 9() Mount the fuse holder in the special D shaped hole. The rubber washer fits between the shoulder and the outside of the chassis. Fasten in place securely, but do not tighten excessively.
- 10() Mount the AC outlet with two sets of #4 hardware.
- 11() Mount the two audio output sockets using two sets of #4 hardware for each. Note the orientation of the ground (outside) lugs in the pictorial.
- 12() Mount one of the two nine pin sockets which have mounting flanges, in the center of the chassis. Note the location of the blank space between the pins in the pictorial. The socket is mounted on top of the chassis with two sets of #4 hardware.
- 13() Mount the multiplex adapter cutout cover plate on top of the chassis using four sets of #4 hardware.
- 14() Install the 3 rubber grommets. The larger one is inserted in the round hole at the rear of the chassis, and the other two are fitted into the round holes in the dividing partition in the middle of the chassis.
- 15() Feed all the power transformer (PA-509) wires through the one-half inch hole as shown in the pictorial. Fasten the transformer in place with four sets of #8 hardware (the largest size). Mount the three lug terminal strip on the power transformer mounting screw (between the hole for the transformer leads and the nine pin tube socket) as shown in the pictorial, and secure it with the same lockwasher and nut.

On completion of this assembly, recheck all hardware to make sure that all components are securely in place.

Chassis Wiring

Unless otherwise specified, the insulation should be stripped from each length of wire for a distance of $\frac{1}{4}$ " at each end prior to installation.

- 1() Strip a $2\frac{1}{2}$ " piece of wire bare. Feed one end through the rear tab of the tuning capacitor C1 that projects through the steel chassis, and then through the other tab, and over to the first tab that projects through the PC-7 board. See pictorial. Solder all three points and trim off the excess.
- 2() Solder all four of the remaining connecting lugs of the tuning capacitor which project through PC-7.

- 3() Twist together the two red and the red-yellow power transformer wires. Connect one red wire to pin #1 of socket V9 (S). Connect the other red wire to pin #7 of socket V9 (S). Dress the red-yellow wire over to the twisted mounting tab on the quadruple section electrolytic capacitor, and connect this wire as shown in the pictorial.
- 4() Connect one end of a 2½" black wire to lug #2 of the three lug terminal strip. Connect the other end to the ground lug of the quadruple section electrolytic capacitor used in the previous step. Solder both wires.
- 5() Connect the green-white transformer wire to lug #2 of the three lug terminal strip. Note that the wire is inserted into the *lower* hole of the lug (S).
- 6() Connect the green transformer wire to lug #1 of the three lug terminal strip. This wire is inserted into the *lower* hole of the lug (S).
- 7() Twist together the two black transformer wires. Connect one wire to lug #2 of the AC outlet. Connect the other wire to lug #2 of the fuse holder (S).
- 8() Connect one end of a 1½" green wire to lug #1 of the three lug terminal strip. Connect the other end to pin #4 of socket V9 (S).
- 9() Connect one end of a 1½" black wire to lug #2 of the three lug terminal strip. Connect the other end to pin #5 of socket V9 (S).
- 10() Connect one end of a 500 ohm 5 watt resistor to lug #1 of the quadruple section electrolytic capacitor. Connect the other end to lug #2 of the capacitor.
- 11() Connect one end of a 2" red wire to pin #3 of socket V9 (S). Connect the other end to lug #1 of the quadruple section electrolytic capacitor (S).
- 12() Connect one end of the other 500 ohm 5 watt resistor to lug #2 of the quadruple section electrolytic capacitor (S). Connect the other end to lug #3 of the capacitor.
- 13() Connect one end of a 470 ohm (yellow, violet, brown) one watt resistor to lug #3 of the quadruple section electrolytic capacitor. Connect the other end to lug #4 of the capacitor.
The following steps will refer to eyelets on the etched circuit boards. Always be certain that you are connecting to the correct point. The electrical requirements of the layout of the circuit board, combined with the tight space allowance, may lead to confusion unless the relationship of numerals and eyelets is carefully observed. Refer to the diagrams of the boards.
- 14() Connect one end of a 6" green wire to lug #1 of the three lug terminal strip. Feed this wire through grommet #1, and connect the other end to eyelet #18 on PC-8 (S). Remember that when soldering to an eyelet, a smooth well-soldered joint must be made from the wire to the eyelet to the copper.
- 15() Connect one end of a 2¾" green wire to eyelet #17 on PC-8 (S). Connect the other end to eyelet #14 (S).
- 16() Connect one end of a 3½" green wire to eyelet #1 on PC-7 (S). Connect the other end to eyelet #5 (S).
- 17() Connect one end of a 7" green wire to eyelet #6 on PC-7 (S). Connect the other end to eyelet #13 of PC-8 (S).
- 18() Connect one end of a 4" green wire to eyelet #19 on PC-8 (S). Connect the other end to eyelet #24 (S).
- 19() Connect one end of a 4¾" red wire to lug #3 of the quadruple section electrolytic capacitor. Feed the wire through grommet #1 and connect the other end to eyelet #22 on PC-8 (S).
- 20() Connect one end of a 7½" green wire to eyelet #20 on PC-8 (S). Feed the wire through grommet #1 and connect the other end to lug #1 of the three lug terminal strip.
- 21() Connect one end of a 6¾" green wire to eyelet #35 on PC-8 (S). Feed the wire through grommet #2 and connect the other end to lug #1 of the three lug terminal strip.
- 22() Connect one end of a 5" red wire to eyelet #21 on PC-8 (S). Connect the other end to eyelet #16 (S).
- 23() Connect one end of a 9" red wire to eyelet #15 on PC-8 (S). Connect the other end to eyelet #9 on PC-7 (S).
- 24() Connect one end of a 7" red wire to lug #3 of the quadruple section electrolytic capacitor. Solder all four wires. Feed the wire through grommet #1 and connect the other end to eyelet #27 on PC-8 (S).
- 25() Connect one end of a 9½" red wire to lug #4 of the quadruple section electrolytic capacitor. Feed the wire through grommet #2 and connect the other end to eyelet #34 on PC-8 (S).
- 26() Twist together a 10" black wire and a 6½" black wire, keeping one pair of ends even. Connect one of the even ends to lug #1 of the on-off switch. Connect the adjacent end of the other wire to lug #2 of the on-off switch. Feed the pair through grommet #2. Connect the other end of the longer wire to lug #2 of the AC outlet (S). Connect the other end of the shorter wire to lug #3 of the three lug terminal strip.
- 27() Connect one lead of the .02 mfd capacitor to lug #1 of the on-off switch (S). Connect the other lead of the capacitor to lug #2 of the switch (S). Place the body of the capacitor under the switch where it is away from the etched circuit board. Refer to the pictorial.
- 28() Connect one end of a 2" black wire to lug #1 of the AC outlet. Connect the other end to lug #1 of the fuse holder (S).
- 29() Connect one end of a 9¼" green wire to eyelet #39 on PC-8 (S). Connect the other end to the center lug of output socket A.
- 30() Connect one end of a 1½" green wire to output socket A center lug (S). Connect the other end to the center lug of output socket B (S). Refer to the Appendix if one of these sockets is to be connected for use with an external multiplex adapter.
- 31() Connect one end of a 5" red wire to lug #4 of the quadruple section electrolytic capacitor. Solder all three wires. Connect the other end to eyelet #12 of PC-7 (S).

PC-7 CIRCUIT

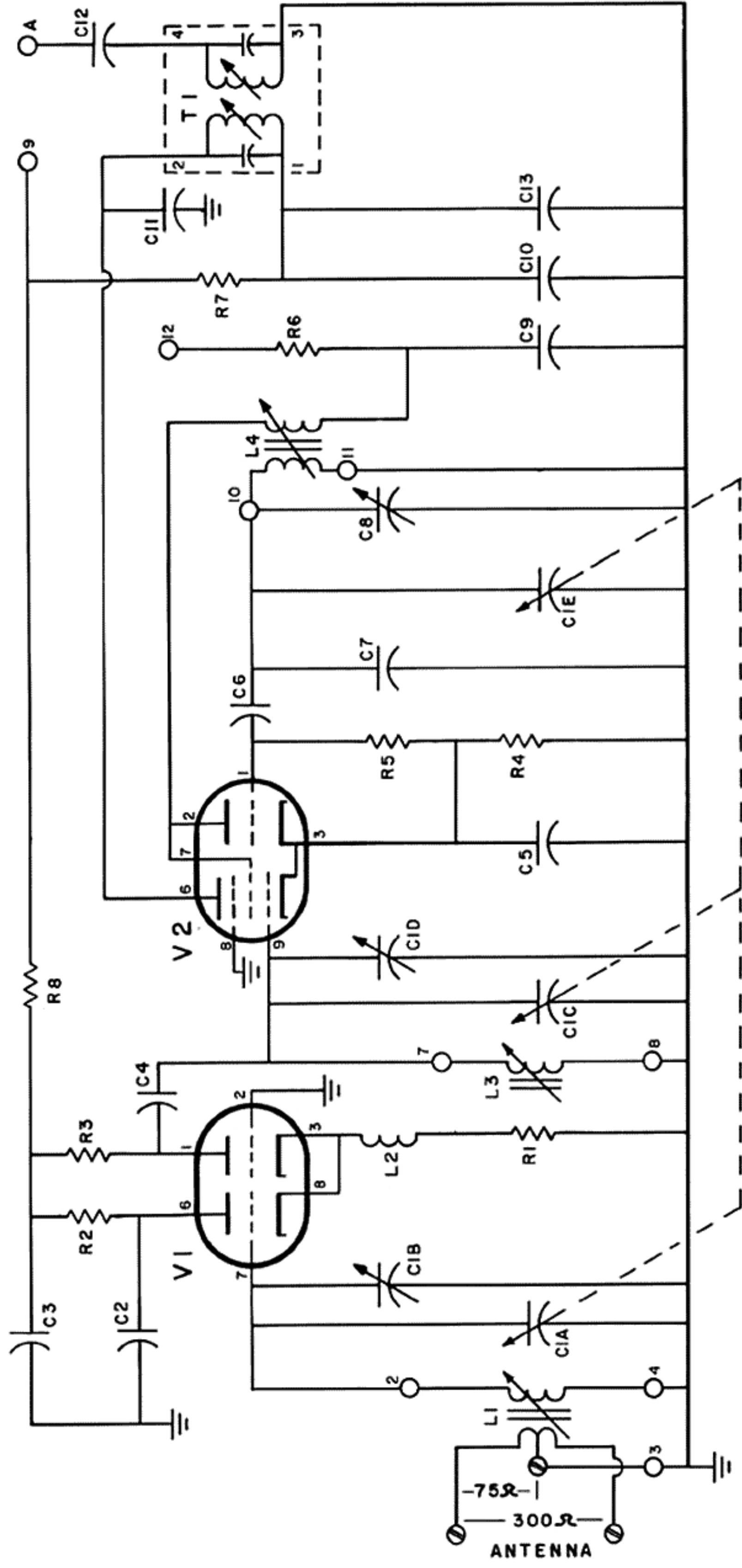

Bob01605@aol.com

PC-8 CIRCUIT

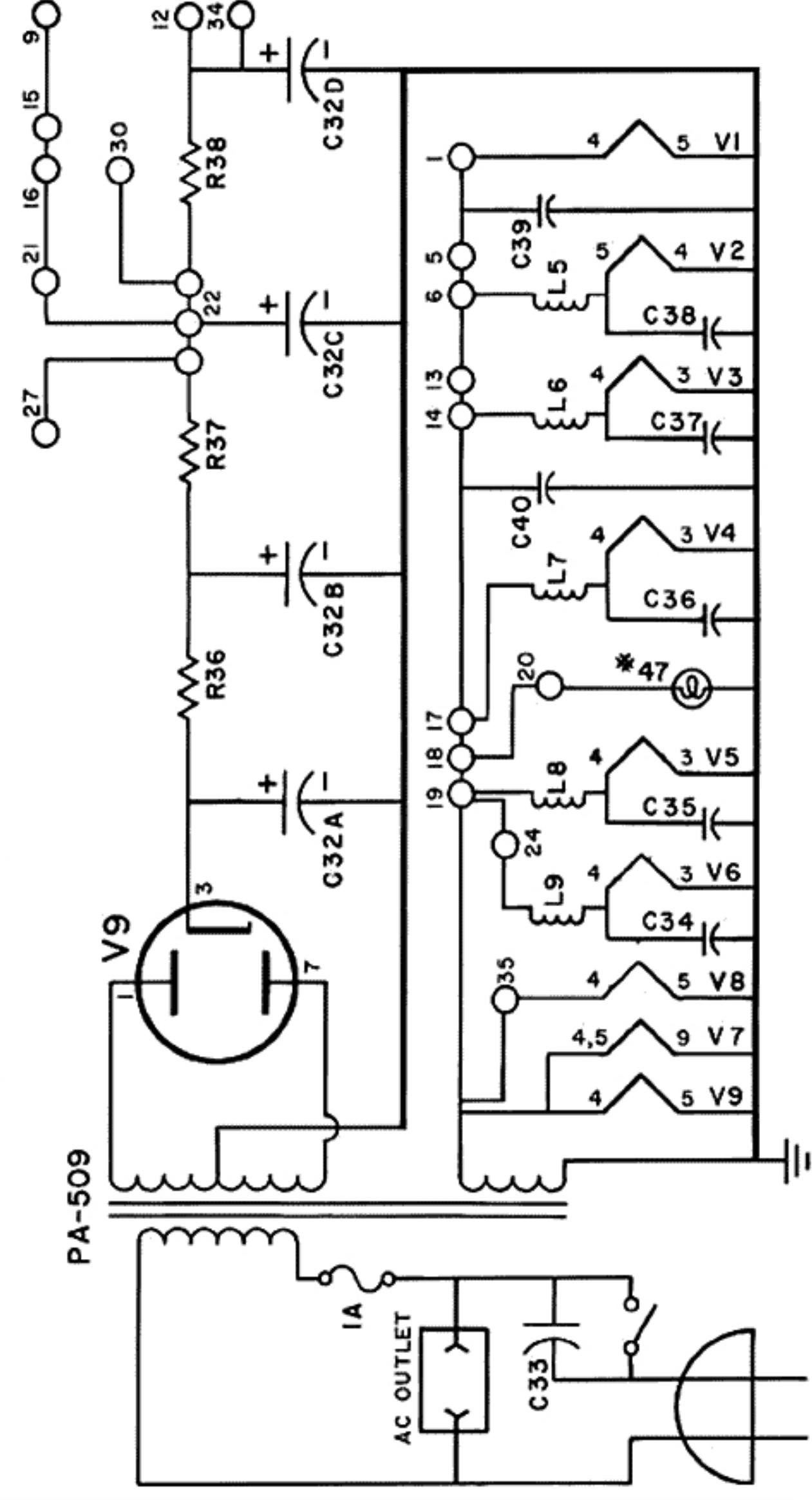
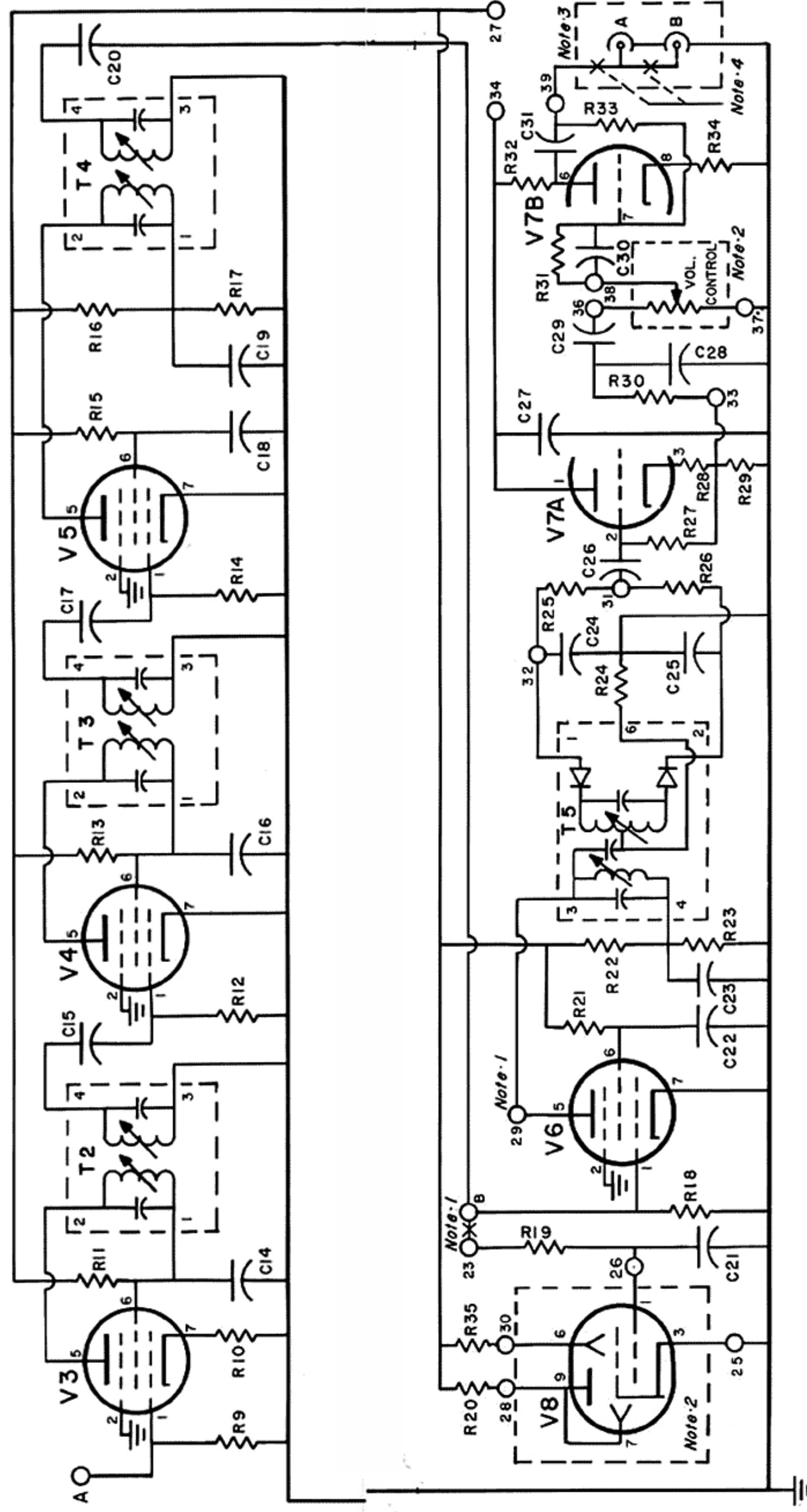

1. TEST POINTS. See Alignment Instructions.
 2. located on front panel
 3. located on rear of chassis
 4. These connections not made when multiplex adapter is used.

NOTES:

SCHEMATIC DIAGRAM

PARTS LIST FOR SCHEMATIC DIAGRAM

All resistors are 1/2 watt 10% unless otherwise noted.

R 1	68 ohms	R 35	68,000 ohms	C 35	.0047 mid
R 2	10,000 ohms	R 36	500 ohm	C 36	.0047 mid
R 3	10,000 ohms	R 37	500 ohm	C 37	.0047 mid
R 4	390 ohms	R 38	180 mhm	C 38	180 mhm
R 5	10,000 ohms	R 39	180 mhm	C 39	180 mhm
R 6	47,000 ohms	R 40	.0047 mid	C 40	.0047 mid
R 7	1,000 ohms	C 1	gangd tuning capacitor	L 1	antenna coil
R 8	1,000 ohms	C 2	180 mhm	L 2	3.9 μh choke
R 9	100,000 ohms	C 3	180 mhm	L 3	mixer coil
R 10	33 ohms	C 4	47 mhm NPO	L 4	oscillator coil
R 11	10,000 ohms	C 5	.0047 mid	L 5	heater choke
R 12	2 watt	C 6	10 mhm NPO	L 6	heater choke
R 13	10,000 ohms	C 7	2.55 mhm N2200	L 7	heater choke
R 14	100,000 ohms	C 8	ceramic trimmer	L 8	heater choke
R 15	330,000 ohms	C 9	.0047 mid	L 9	heater choke
R 16	220,000 ohms	C 10	.0047 mid	T 1	I.F. transformer
R 17	62,000 ohms	C 11	2.2 mhm	T 2	I.F. transformer
R 18	100,000 ohms	C 12	47 mhm	T 3	I.F. transformer
R 19	3.3 megohms	C 13	180 mhm	T 4	I.F. transformer
R 20	680,000 ohms	C 14	.0047 mid	T 5	Discriminator transformer
R 21	100,000 ohms	C 15	330,000 ohms	V 1	6AG6/ECC85
R 22	47,000 ohms	C 16	220,000 ohms	V 2	6AT8A
R 23	47,000 ohms	C 17	62,000 ohms	V 3	6BA6
R 24	47,000 ohms	C 18	47 mhm NPO	V 4	6BA6
R 25	3,900 ohms	C 19	47 mhm NPO	V 5	6AU6/EF94
R 26	62,000 ohms 5%	C 20	47 mhm NPO	V 6	6AU6/EF94
R 27	62,000 ohms 5%	C 21	.01 mfd	V 7	12AX7/ECC83
R 28	1.2 megohms	C 22	.0047 mid	V 8	6FG5/EM84
R 29	390 ohms	C 23	.0047 mid	V 9	6V4/EZ80
R 30	8,200 ohms	C 24	47 mhm NPO	PA-509	power transformer
R 31	10,000 ohms	C 25	47 mhm NPO	volume control	250,000 ohms
R 32	100,000 ohms	C 26	.01 mfd	fuse	1 ampere
R 33	330,000 ohms	C 27	100,000 ohms	pliot light	—#47
R 34	1,000 ohms	C 28	.02 mfd		
R 35	.0047 mid	C 29	36		
R 36	500 ohm	C 30	27 mhm		
R 37	500 ohm	C 31	22 mid @ 200 v.		
R 38	180 mhm	C 32	40/40/20/20 mfd @ 350 v.		
R 39	180 mhm	C 33	.02 mfd		
R 40	.0047 mid	C 34	.0047 mid		

- 32() Connect one end of a 1½" green wire to eyelet A of PC-7 on the top of the board. Solder it from the bottom of the board. Connect the other end to the top of eyelet A on PC-8 and solder it from the bottom.
- 33() Connect the end of the bare wire from eyelet #3 on PC-7 to lug #2 of the three screw terminal strip.
- 34() Connect the wires from each side of antenna coil L1 to the screw terminal nearest it. Observe the wire arrangement in the pictorial diagram. Follow it precisely. Solder the wires to screw terminals #1 and #3. Connect the twisted wire from the center of the antenna coil L1 to lug #2 of the terminal strip (S).
- 35() Connect a 1" bare wire from eyelet #23 on PC-8 (S) to eyelet B (S). This jumper should be kept close to the bottom of the board.
- 14() Connect the free end of the green wire from the volume control to eyelet #38 on PC-8. This wire is connected on top of the board and soldered from below.
- 15() Connect the free end of the red wire from the volume control to the top of eyelet #36 on PC-8, and solder it from below. Eyelet #36 is located between the 100,000 ohm resistor (brown, black, yellow) and the mylar capacitor C29. Position the leads as shown in the pictorial, and keep them clear of the board.
- 16() Connect the free end of the black wire from pin #3 of socket V8 to the top of eyelet #25 on PC-8, and solder it from below.
- 17() Connect the free end of the green wire from pin #1 of socket V8 to the top of eyelet #26 on PC-8 and solder it from below.

Front Panel Assembly

- 1() Mount the nine pin socket which has a mounting flange, on the top of the right angled section on the rear of the front panel. Use two sets of #4 hardware. Check the pictorial for the proper position of the blank area between the pins.
- 2() Place the ⅜" lockwasher on the shaft of the volume control and insert the control into its hole in the front panel. Locate the lugs as shown in the pictorial. Fasten loosely with a ⅜" nut.
- 3() Connect one end of a 2" black wire to lug #1 of the volume control (S).
- 4() Connect one end of a 2½" green wire to lug #2 of the volume control (S).
- 5() Connect one end of a 3" red wire to lug #3 of the volume control (S).
- 6() Twist together a 9" black wire and a 9" green wire. Connect one end of the black wire to pin #5 on socket V8 (S). Connect the adjacent end of the green wire to pin #4 on socket V8 (S).
- 7() Connect one end of a 2½" black wire to pin #3 of socket V8 (S).
- 8() Connect one end of a 2" green wire to pin #1 of socket V8 (S).
- 9() Connect one end of a 3" red wire to pin #6 of socket V8 (S).
- 10() Cut a 2" red wire. Strip one end ½". Feed the longer bared end through pin #9 of socket V8 and connect it to pin #7. Solder both pins.
- 11() Slide the tuning dial indicator disc fully onto the tuning capacitor shaft. The hub goes on the shaft first, and its flat side engages the flat section of the brass shaft.
- 12() Feed the twisted black and green wires from the socket on the front panel through the small slot in the front of the chassis. Fasten the front panel to the main chassis with three sets of #4 hardware.
- 13() Twist together the three wires from the volume control. Connect the free end of the black wire to eyelet #37 on PC-8. Feed the wire through the eyelet from the top of the board, and solder it from below. At eyelet #37 a large amount of solder should be flowed onto the board, and over to the chassis, to make a good ground contact to the chassis.
- 18() Connect the free end of the red wire from pin #6 of socket V8 to the top of eyelet #30 on PC-8 and solder it from below.
- 19() Connect the free end of the red wire from pin #9 of socket V8 to the top of eyelet #28 and solder it from below. Eyelet #28 is between T5 and the 680,000 ohm resistor (blue, gray, yellow).
- 20() Mount the discriminator transformer T5 (432002). This transformer has five connecting lugs and two mounting tabs. It can only be mounted in one position. Press it firmly to the board and solder the mounting tabs and the five connecting lugs. Do not use excessive heat on the five lugs. Avoid using too much solder, which could flow into and damage the transformer.
- 21() Thread the black and green pair of wires from socket V8 through grommet #2 and connect the black wire to lug #2 of the three lug terminal strip. Solder all three wires at the top of the lug. Connect the green wire to lug #1 of the three lug terminal strip. Solder all five wires at the top of the lug.
- 22() Insert the end of the line cord through grommet #3 in the rear of the chassis and pull through about 6 inches. Tie a knot 4 inches from the end, and pull the line cord back so that the knot seats against the grommet. Split the two conductors of the line cord down to the knot. Connect one of the two leads to lug #1 of the AC outlet (S). Connect the other lead to lug #3 of the three lug terminal strip (S).

The wiring of the tuner is now completed. It is wise at this point to go back and check all solder connections in the unit. One poor solder connection can upset the performance of your tuner. Check to be sure that the position of the wires in your tuner agrees closely with the pictorial diagram and the photographs. The pictorial diagram must necessarily be exaggerated in some cases for clarity, but any discrepancies between it and the photographs are of no consequence. All of the leads should be neatly dressed along the chassis.

Insert the tubes in their respective sockets as shown in the pictorial diagram. Install the tube shields, making certain that the ground straps on the sockets slip between the shield and the tube. The larger tube shields go on the nine pin tubes and the smaller ones on the seven pin tubes. No shields are used on V8 or V9. Install the dial light and the fuse.

There are two small brass-plated self-tapping screws which will be used to secure the brass front plate to the front panel. To avoid scratching the brass plate, it is wise at this point to cut their threads in the holes above and below the tuning capacitor shaft by inserting these screws and removing them. This will enable much easier insertion when the front plate is installed.

Peel off the protective plastic film on the face of the brass front plate. Remove the $\frac{3}{8}$ " nut holding the volume control to the front panel. Insert the rectangular plastic insert into the front plate cutout from the rear (the top edge is narrower than the bottom). Place the front plate against the steel front panel so that the plastic insert is held between the two plates, and the volume control shaft and the tuning capacitor shaft protrude through both panels. Install the $\frac{3}{8}$ " nut on the volume control shaft and tighten it. Secure the front plate to the panel with the two brass self-tapping screws above and below the tuning shaft. Rotate the volume control shaft fully counter-clockwise and install the small knob with the pointer at the 7 o'clock position. The knob is pushed onto the knurled shaft. Fasten the large knob onto the tuning capacitor shaft by tightening the set screw.

ALIGNING YOUR DYNATUNER

The Dynatuner is unique in its simplicity of alignment. It can be aligned using the tuning eye as an indicating instrument, and this alignment is as precise as can be accomplished with the most complex laboratory equipment. It is important to emphasize that when this procedure has been carefully followed, it is not possible to "improve" on this alignment, and the Dynatuner will meet the most rigorous performance standards. It is essential that any serviceman who works on this tuner be informed of this procedure, and that he is also advised that conventional "sweep" alignment techniques are not considered either satisfactory or desirable.

Certain parts of the Dynatuner have been preset close to the proper alignment point. All of the I.F. transformers, the discriminator transformer, and the slug-tuned coils on the R.F. board PC-7 are preset. Several approximate adjustments should be made first, which will permit reception of local stations, and then complete alignment can be carried out.

- 1() The oscillator trimmer capacitor C8 screw (accessible from below the chassis) should be turned until the head of the screw is $\frac{5}{16}$ " from the triangular nut.

On the top of tuning capacitor C1 there are two adjustment screws (trimmer capacitors) accessible through the two holes in the top of the tuning capacitor shield. The center screw (C1-D) adjusts the mixer, and the rear screw (C1-B) adjusts the R.F. stage. *The approximate settings given in steps #2 and #3 below have already been made as the capacitor is supplied to you.*

- 2() Turn in the screw C1-D on the center (mixer) section until it is in all the way. It should be snug, but do not force it. Then back it off $\frac{1}{4}$ turn counter-clockwise.
- 3() Turn in the screw C1-B on the rear (R.F.) section until it is in fully, but do not force it. Then back it off $\frac{1}{8}$ turn counter-clockwise.

Now you should make one final inspection of the unit to see that all connections are soldered, that there are no loose wire clippings or pieces of solder, and that there are no parts hanging in the air. Also check to make certain that there are no bridges of solder across the insulated areas of the circuit boards. If everything appears to conform to the pictorial diagrams and photographs, plug the Dynatuner in (to AC current sources only) and turn it on.

With an antenna attached, and an audio connecting cable between the tuner and an amplifier or preamplifier as described in the section "Using Your Dynatuner", you should turn the volume control knob on the tuner fully counter-clockwise and then turn on the on-off switch. The dial light should light, and there should be a slight glow visible in each tube as its heater lights, and then the tuning eye should glow. All of this will take only about 15 seconds. When turning the tuning knob, some deflection of the tuning eye should be apparent as the tuning passes through the frequencies of local stations. By turning the volume control knob clockwise, it should be possible to hear some hiss between stations and sound from the stronger stations. If all these effects cannot be obtained, refer to the section "In Case of Difficulty" before attempting to use the tuner further or to align it.

As soon as it is evident that there is reception of some stations, we suggest that you leave the tuner operating for about an hour to let the tubes age and for operating conditions to stabilize. This will eliminate the need for re-alignment after alignment is carried out. You should be able to enjoy the use of the tuner during this time since normally reception will be quite adequate on local stations.

The alignment tools to be used are: a plastic tool (supplied) which has a hexagonal end for adjustment of the tuning slugs in the I.F. and discriminator transformers, and a small tipped screwdriver with an insulated handle. *Only* the plastic tool should be used to adjust the transformers. Any other type of instrument will damage the tuning slugs. When using the plastic alignment tool, all adjustments are made using the end which has a shoulder to prevent inserting the tool too far.

BE CAREFUL IN HANDLING THE CHASSIS DURING ALIGNMENT. THERE IS SOME SHOCK HAZARD DUE TO THE EXPOSED WIRING.

It is suggested that before proceeding, you read these instructions over completely, to familiarize yourself with the general procedure. The tuner is to be connected to an amplifier and speaker, turned on, and the antenna attached as for normal use.

I.F. Alignment

When making these adjustments, turn the slug back and forth over a narrow range. Do it slowly and carefully to obtain the correct point with precision. If everything is normal, it is not necessary to make more than a small adjustment to reach the right point. **IF YOU HAVE TO TURN PAST ONE FULL TURN YOU ARE PROBABLY COMPENSATING FOR SOME FAULT IN WIRING OR COMPONENTS, AND YOU SHOULD STOP TO RECHECK BEFORE PROCEEDING. DO NOT APPLY EXCESSIVE FORCE WHEN TURNING THE SLUGS.**

- 4() Set the tuning knob to a point where no station can be heard (only hiss). Insert the plastic alignment tool into the top of I.F. transformer T4, and adjust for the point of loudest hiss. If you find it difficult to locate the peak, turning on a nearby vacuum cleaner or electric shaver may simplify the task.

The sharpness of the point of correct tuning will increase as you proceed. The hiss will get louder, and you can control it for a comfortable level with the volume control. As the adjustment proceeds, some indication will become visible in the tuning eye, and you will note that the eye closes to some extent as the hiss increases. When this effect is noted, you should make all further adjustments using the maximum closing of the eye to tell you what is the proper alignment point.

Always use the shoulder end of the alignment tool for this work. The following 7 steps all refer to the adjustment procedure described here.

- 5() Adjust the bottom slug of T4.
- 6() Adjust the top slug of T3.
- 7() Adjust the bottom slug of T3.
- 8() Adjust the top slug of T2.
- 9() Adjust the bottom slug of T2.
- 10() Adjust the top slug of T1.
- 11() Adjust the bottom slug of T1.

Discriminator Alignment

The alignment of the discriminator controls the distortion of the entire tuner. The Dynatuner has a positive adjustment technique for this critical part of the alignment.

- 12() Tune a strong signal (station) *very carefully* to get the precise point of maximum eye closing.

Make sure that you *do not disturb the setting of the tuning knob* during the following adjustments, as it is important for the tuner to be accurately tuned. The eye will no longer indicate the exact tuning point, as it will be serving other functions.

- 13() Unscrew (counter-clockwise) the top slug of the discriminator transformer T5, using the shoulder end of the plastic alignment tool. Unscrew this until the top of the slug is flush with the top of the transformer.

This procedure has detuned the secondary winding of the discriminator transformer—a step which is essential in order to obtain the optimum adjustment of its primary winding which is the next step.

At this point the tuning eye must be connected to another part of the circuit in order to measure the correct tuning point of the discriminator primary (as set by the bottom slug). *If you are careful*, it is possible to unsolder, and resolder the required wires in this step and several succeeding steps without turning off the tuner. However, **YOU MUST BE CONSCIOUS OF THE POSSIBLE SHOCK HAZARD FROM THE EXPOSED WIRING.** If you wish to avoid all risk of shock, you can turn the tuner off, make the connections, and turn it on again. However, it is *essential* that you give the set a few minutes to warm up thoroughly after any time that you turn it off, even if the off-time is only a minute or less.

If a VTVM is available, discriminator alignment can be simplified by following the instructions given in small type, in place of steps 14 through 23. The VTVM should be of a type which has at least a 1 megohm resistor in the DC probe to isolate the probe and lead capacity from the measured circuit.

Connect the VTVM between eyelet #32 and the chassis, and adjust the bottom slug of T5 for maximum negative voltage (about -8 volts). Now connect the VTVM to eyelet #31. Turn the top slug of T5 in 9 full turns as a first approximation. Now adjust this slug so that an accurate zero reading is obtained. It is essential that you go through zero first, then locate it precisely. Use the maximum sensitivity scale on the meter.

- 14() Unsolder and lift off the jumper wire which connects from eyelet #23 on PC-8 to eyelet B.
- 15() Temporarily solder a wire from eyelet #23 to eyelet #32 on PC-8.
- 16() Adjust the bottom slug of T5 for maximum closing of the eye.
- 17() Unsolder the end of the temporary wire from eyelet #32 and temporarily connect it to eyelet #31.
- 18() Solder a 2" piece of bare wire to the center ground pin of socket V7.
- 19() Turn the top slug of T5 in (clockwise) 9 full turns, which brings it close to the proper adjustment point.
- 20() Touch the free end of the wire from the center ground pin of V7 to eyelet #31. You will observe that there is a deflection of the eye (either inward or outward). Rotate the top slug of the discriminator transformer T5 back and forth slowly while *alternately touching and releasing* the free end of the wire from the center ground pin of V7 to eyelet #31. The actual adjustment of the slug must be made while the wire is *not* touching the eyelet. Check the eye's deflection *after* each change. You are seeking the precise point where there is *no shift in the eye* as the wire is touched to, and removed from, eyelet #31. There may be slight changes in the brightness of the eye as this is done, but these are of no consequence. Turn the slug in the direction which minimizes the shift in deflection until there is no shift when the wire makes or breaks contact with eyelet #31.
- 21() Remove the temporary wire between eyelets #23 and #31.
- 22() Re-connect the jumper wire from eyelet #23 to eyelet B. Keep it reasonably close to the board.

- 23() Remove the wire from the center ground pin of socket V7.
- 24() Cut a piece of wire *exactly* 15/16" in length. Strip *exactly* 1/4" of insulation from one end. The other end need not be stripped. Insert the stripped end *fully* into the bottom of eyelet #29 (S). This wire should stand up straight from the PC-8 board with the other end free, to a height of 11/16". Dress adjacent wires away to permit this wire to stand straight without touching any others.

This wire may seem to be unusual, as it is connected at one end only. However, it is what is known in electronic parlance as a "gimmick" and it is actually a small capacitor which corrects for the effects of interaction between the adjustments of the two slugs in the discriminator transformer. At such time as realignment is performed, this "gimmick" should be removed before aligning the discriminator.

Alignment of the Front End

The oscillator must now be adjusted. In this section, dial tracking will be simplified if another FM radio is available to enable you to identify stations readily.

- 25() Place the bottom plate on the tuner. See that the side holes are aligned with the chassis holes, for correct orientation.
- 26() Turn the tuning knob until you have located an FM station of known frequency at the high end of the band (close to 108 megacycles), the higher the better.
- 27() Adjust the oscillator trimmer capacitor C8 through the hole in the bottom plate, using a small screwdriver. At the same time readjust the tuning knob until the station's frequency is indicated in the plastic window by the tuning dial. In other words, you set the dial to show the correct frequency and adjust the trimmer capacitor until the eye closes to a maximum.
- 28() Now find a station of known frequency at the lowest end of the dial (close to 88 megacycles). Using a small screwdriver, and touching only the insulated handle, adjust the brass slug in the oscillator coil L4 while setting the tuning dial to the station's broadcast frequency. This is the same type of adjustment as was made in the preceding step.

It may be necessary to repeat the adjustments at the two extremes of the dial several times in order to have the tuner "track" properly. If the adjustments are not made accurately, the dial readings will not coincide with station frequencies across the dial.

- 29() Tune accurately to a station near 108 megacycles and adjust the two trimmer capacitors C1-B and C1-D on the top of the tuning capacitor. The screwdriver should not touch the capacitor shield when making these adjustments. The adjustment should be made for maximum eye closing. If the eye is closed to its normal maximum, the effects of these adjustments will not be readily apparent, so it is *essential* that a weak signal be used here (where the eye is about 1/4" open) or proper alignment will not be realized.

To obtain a sufficiently weak signal, it may be necessary to remove the antenna and substitute a short piece of wire. Shorting out half the antenna is another alternative. With signals of this magnitude (a very few microvolts) it will be noticed that the eye is sensitive to flutter as a result of airplanes passing overhead, or varying signal strength as a result of atmospheric conditions. Care must be taken not to allow this sensitivity to influence the actual adjustment of C1-B and C1-D.

- 30() Tune carefully to a station near 88 megacycles and adjust the two brass slugs in the mixer coil L3 and the R.F. coil L1 for maximum eye closing.

The last two adjustments should be repeated, since there is interaction between adjustment of the trimmer capacitors and the slugs of the coils. This adjustment of L1 and L3 is not critical, and may be a broad peak, necessitating an approximate center setting.

This completes the alignment of your Dynatuner. No further alignment should be required unless there is a change in tubes or components. At that time, you have the means of re-aligning it so that your Dynatuner will always be at the very peak of its performance capability. However, one word of caution is in order—do not make these adjustments unnecessarily, as the various slugs will eventually loosen and cause tuning shifts to the detriment of performance. Alignment adjustments should be considered as a semi-permanent type of adjustment, and not an operational adjustment.

After completion of alignment, install the rubber feet in the corner holes of the bottom plate, and secure the bottom plate and the cover with the four sheet metal screws. The flange on the front of the cover goes between the steel front panel and the brass front plate.

Your Dynatuner is now ready for long pleasureable use.

IN CASE OF DIFFICULTY

In the event that your first attempt at listening to your Dynatuner is unsuccessful, a systematic approach to locating the difficulty will save you much time and trouble.

Because 90% of the difficulties which are encountered can be attributed to either incorrect wiring or a poor solder connection, it is strongly recommended that you first ask someone else to check the wiring against the pictorial diagrams, as frequently one person will make the same error twice.

Drift, or shifting of the tuned signal frequency, should be cause to suspect poor mounting or soldering of C7 or C8, or a defective 6AT8A tube.

If the dial light and tubes do not light when the set is plugged in and turned on, check to see if the fuse is all right. A continuity test at the prongs of the line cord with a meter will show if the fuse, on-off switch, and power transformer primary winding are all properly connected into the circuit.

If the one ampere fuse blows when the set is turned on, remove all the tubes, install another one ampere fuse and try again. If a replacement fuse of the same size blows when all of the tubes are removed, the trouble is either in the wiring to the transformer's black leads, or in the transformer itself.

If the tubes light, but not the dial light, the light may be defective, or the wires which lead to it via the etched circuit board may be open.

If tubes light and the eye tube shows a lighted filament, but the eye does not have a blue-green glow on the front screen (which is visible through the plastic insert in the front panel) check the wiring around the tuning eye socket. If this is all right, the fault may be in the power supply, and the rectifier tube V9 and the associated wiring should be checked. If the eye glows, the power supply wiring can be assumed to be correct.

If the eye deflects as the tuning dial is turned, this is an indication that the R.F. stages and the I.F. stages are working. If no sound is heard, but the eye deflects, the difficulty lies in either V7 (12AX7) or the components associated with it, including the volume control. If V7 is functioning properly, touching either pin #2 or pin #7 of the socket with the point of a screwdriver should produce a pop or hum through the hi fi system. If it does not, touch the audio output cable ends when they are removed from the tuner sockets. This will check the cable and the following equipment. If they are working, hum will be heard when the cable end is touched.

If the tuning eye does not deflect when the tuning knob is turned, the difficulty is probably on PC-7. Tube V2 should be checked. If a very faint hiss can be heard, it is possible that *slight* readjustment of the screws on top of the tuning capacitor will bring up the signal level so that indications are normal and the alignment procedure can be begun.

Frequently difficulties in the I.F. strip (PC-8) can be localized by touching the #1 pin of each I.F. tube in the sequence V6, V5, V4, V3. A noise or thud should be heard each time the #1 pin is touched, and the tuning eye should deflect. If you find a #1 pin which does not produce a noise, then look for the difficulty between that point and the previously tested #1 pin.

If the tuner operates and can be aligned, but has hum in the signal, there are several tests to be made. If there is hum even when the volume control is turned down, unplug the tuner from the associated equipment and see if the hum disappears. If it does not, the fault lies in the associated equipment. If it does disappear, then the hum is most likely to be associated with V7. The circuit should be inspected and the 12AX7 checked, preferably by substitution. If the hum is part of the signal and disappears when the volume is turned down, try several stations, as it is possible that the one used as a test signal is broadcasting some hum. If hum occurs on all stations, the 6AT8A may be faulty and should be checked (preferably by substitution).

If there is apparent distortion in the signal, make sure that this is not a momentary effect because of poor transmission. If it persists, compare the same system with phonograph or tape as a different program source to see if the effect can be localized to the tuner. If it is definitely in the tuner, it may be caused by improper discriminator

alignment, and this portion of the alignment procedure should be repeated.

In the course of trouble shooting, inspect very carefully for "bridges" of solder from one point to another. Also recheck for correctness of component positions on the printed circuit boards. Many defects of this type, as well as faulty components can be ascertained by voltage measurements, and a complete voltage chart is provided. Any deviation of 20% or more from this chart is evidence of possible defects. Examination of components in the area of incorrect voltage (with reference to the schematic diagram) should help to uncover the difficulty.

Normal radio servicing techniques of signal injection and signal tracing are appropriate for localizing troubles, but for best alignment, the procedure specified in these instructions should be followed. However, if servicing is done by a qualified technician, he can expedite alignment by setting the I.F. transformers for peak eye deflection using a *very low* level 10.7 mc signal. The strength of this signal should be sufficient to actuate the eye, but not to close it to its normal maximum. Discriminator alignment must follow the technique described in these instructions. Conventional sweep techniques should not be used.

APPENDIX

Your Dynatuner as an FM Receiver

An accessory 10 watt amplifier, the FMA-2, is available to fit the multiplex adapter space on your Dynatuner to convert it to a complete FM receiver, requiring only a loudspeaker. The volume control on the tuner is used, and power is drawn from the tuner power supply. Operation as a component tuner is not affected. Further information can be obtained from Dynaco, Inc.

Multiplex Provisions

Your Dynatuner is fully prepared for multiplexed stereo reception. The FMX-3 Dynakit Multiplex Integrator can be installed in the chassis cutout provided, and the power supply has been designed with adequate reserve for the adapter's requirements. Most important, however, is the tuner's design for adequate bandwidth to handle full fidelity multiplex reception, necessitating flat response well beyond the audio range.

The FMX-3 Integrator will include all necessary inter-connection instructions. The A and B output sockets will then provide the two stereophonic channels, or the monophonic signal when a station is not broadcasting stereo.

The B output socket can be connected to provide a .75 volt isolated signal from the low impedance cathode follower output of the discriminator without de-emphasis for use with external multiplex adapters. For this arrangement, remove the wire between the center lugs of output sockets A and B, and connect a wire from eyelet #33 of PC-8 to the center lug of output socket B. If the external adapter contains an input blocking capacitor (.001 mfd or greater) no other connections are required.

If the adapter does not have a blocking capacitor in series with the input, it is generally simplest to install it in the adapter. Alternatively, a .001 mfd capacitor can be installed in series with the B output lead, using a one lug terminal strip which may be bolted to the chassis with the cover plate hardware.

Indoor Folded Dipole Antenna

Measure and cut a $58\frac{1}{2}$ " length from the 10 feet of 300Ω twin-lead supplied with this kit.



Strip the insulation from both wires back $\frac{1}{2}$ " at each end.



Twist the exposed wire ends together and solder.



Fold the wire to find the middle, and make a "T" cut, cutting through the bottom wire as shown. Strip the insulation from the wire ends, exposing $\frac{3}{8}$ " of bare wire at both sides of the cut.

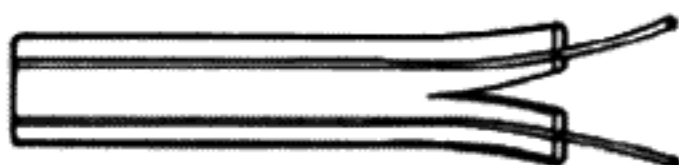
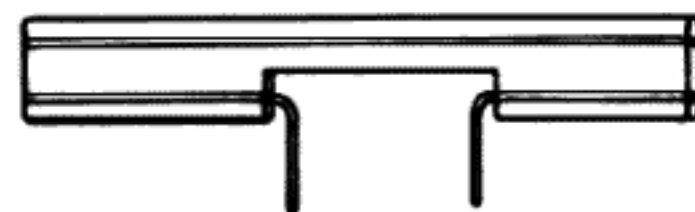

Slit the center webbing down the middle for one inch on one end, and strip off $\frac{1}{2}$ " of insulation from both ends of the remaining piece of twin-lead.

Connect each of the wires from one end of the lead-in wire to the center of the antenna wire. Twist together and solder. The end marked "A" is connected to the two outer antenna screws (marked 300Ω on the bottom plate) of your Dynatuner. Do not connect this type of antenna to the center screw.

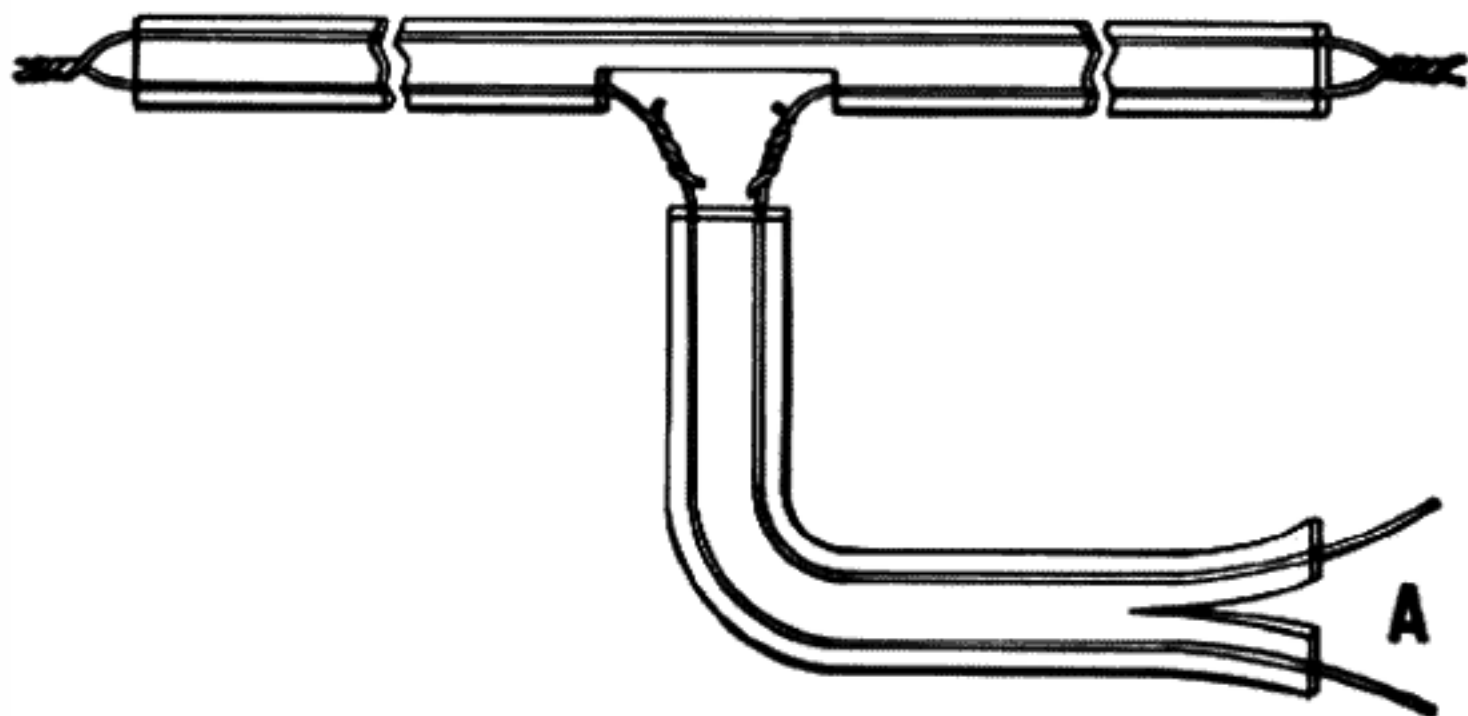

The extreme sensitivity and quieting ability of the Dynatuner will enable you to receive most signals using this folded dipole. The antenna section should be supported in a horizontal position in a straight line, and can be taped or tacked to a convenient surface or placed beneath the rug. The antenna should be kept away from any metal which might tend to absorb the signal.

A simple folded dipole of this type has its maximum response at right angles to the antenna wire. Therefore, best reception from a given direction will be achieved by rotating the antenna so that it points 90° from the desired direction of reception.

FACTORY SERVICE AND GUARANTEE

The Dynatuner FM-1 is designed to provide good service over a long period of time. It is intended to be used at the conventional 117 volt AC line input found in most homes. Operation up to 125 volts will not cause any problem. Above that voltage, it is suggested that a voltage regulating or adjusting device be used in order to protect the components in your tuner. The normal guarantee on the equipment is not applicable if it is used above the 125 volt rating.

All parts in the FM-1 are guaranteed for a period of one year from purchase except tubes which carry the standard EIA guarantee of 90 days. Parts which are defective will be replaced at no charge if they are returned prepaid to the factory either directly or via the dealer from whom the kit is purchased. Many Dynaco dealers carry spare parts in stock to facilitate replacements. After the guarantee period is past, Dynaco will supply any non-standard parts used at net prices. Parts which are standard dealer items can be purchased from most electronic supply stores.

If the PA-509 transformer is returned for factory repair or exchange, it should be removed from the tuner without cutting the leads short. If leads have been cut rather than unsoldered, so that they are no longer usable, the guarantee on the transformer is voided.

In the event that the assembled tuner does not function properly or breaks down after some use, Dyna Company will service the tuner for a fixed service fee plus the cost of parts which have been damaged by the user or are past the guarantee period. The service fee is \$10.00 and includes necessary repairs, checkout, and alignment. If only checkout and alignment are required, the service fee is \$5.00. This service facility is not available for kits which are incompletely wired, or have been wired with other than rosin core solder, or in which changes or modifications have been made without factory authorization. In addition, **NO PARTS WILL BE REPLACED NOR WILL ANY SERVICE BE AVAILABLE FOR KITS WHERE THE GUARANTEE POST CARD HAS NOT BEEN RETURNED. THE SERIAL NUMBER ON THIS INSTRUCTION BOOK MUST BE MENTIONED IN CORRESPONDENCE, PARTS RETURN, OR KITS RETURNED FOR FACTORY SERVICE.** It is the factory prerogative to limit the service facility to one year from date of purchase. There is no charge for service of factory wired tuners during the first year, but the unit must be shipped prepaid and will be returned freight collect.

When shipping the tuner for service, a note must be attached specifying the symptoms, the name and address of the sender, and the serial number of the unit. It should be securely packed with stuffing inside the cover to prevent the tubes from falling out of the sockets. It should be placed in a rugged carton surrounded by several inches of shredded paper or other soft packing material. The original kit carton is not suitable for shipping a wired tuner.

Shipment should be made by prepaid Railway Express, where possible. Returns will be made COD for freight and repair costs unless these have been prepaid.

Dyna Company assumes no responsibility or liability for damages or injuries sustained in assembly or operation of the Dynatuner.

PARTS LIST

The parts listed here are in addition to the parts lists included with the pictorial diagrams of PC-7 and PC-8. A complete inventory will include all three sections.

- 1 Chassis set
(main chassis, front panel, bottom plate, cover, tuning capacitor shield, and multiplex adapter cover plate)
- 1 Power transformer—PA-509
- 1 Tuning capacitor, ganged—C1-A, -B, -C, -D, -E
- 1 Slide switch, on-off, SPST
- 1 AC outlet
- 1 Fuse holder with rubber washer and nut
- 1 Fuse, 1 amp
- 1 3 screw terminal strip
- 1 3 lug terminal strip
- 1 pilot lamp #47
- 1 Line cord
- 1 Volume control, 250,000 Ω
- 2 output sockets
- 1 Audio cable shielded
- 2 9 pin tube sockets with flanges—V8 and V9
- 3 pieces hook-up wire (red-black-green)
- 1 piece twin-lead wire for antenna
- 1 quadruple section electrolytic capacitor—C32
(40/40/20/20 @ 350 volts)
- 1 .02 disc capacitor—C33
- 2 500 ohm 5 watt resistors—R36 and R37
- 1 470 ohm (yellow, violet, brown) 1 watt resistor—R38
- 1 Instruction Manual
- 1 Guarantee Card

HARDWARE

- 4 #6 x 1/4" sheet metal screws
- 2 #4/40 x 5/32" self-tapping screws
- 4 #8/32 x 3/8" machine screws
- 4 #8 lockwashers
- 4 #8/32 nuts
- 1 3/8" lockwasher
- 1 3/8" nut
- 37 #4/40 x 1/4" machine screws
- 35 #4/40 nuts
- 35 #4 lockwashers
- 4 #6/32 nuts
- 4 #6 lockwashers

TUBES

- 1 6AQ8/ECC85—V1
- 1 6AT8A—V2
- 2 6BA6—V3 and V4
- 2 6AU6/EF94—V5 and V6
- 1 12AX7/ECC83—V7
- 1 6FG6/EM84—V8
- 1 6V4/EZ80—V9
- 4 tube shields for 7 pin sockets
- 3 tube shields for 9 pin sockets
- 3 rubber grommets
- 4 rubber feet
- 1 large knob
- 1 small knob
- 1 plastic alignment tool
- 1 tuning indicator dial disc
- 1 plastic insert for front plate
- 1 brass front plate

Parts of similar type which do not change performance may sometimes be included as a matter of expediency. This will account for slight variations in value and appearance.

VOLTAGE CHECK POINTS

All voltages are measured with the volume control at minimum and the dial tuned between stations (no signal) since many of the voltages will vary widely under different signal conditions. All voltages are measured between the point indicated and the chassis, using a vacuum tube voltmeter.

TUBE	PIN#								
	1	2	3	4	5	6	7	8	9
V 1 6AQ8/ECC85	145 DC	0	.8 DC	6.3 AC	0	145 DC	0	.8 DC	0
V 2 6AT8A	-3 DC ¹ *	52 DC	2 DC	0	6.3 AC	220 DC	52 DC	—	0
V 3 6BA6	-.2 DC ¹	0	0	6.3 AC	85 DC	85 DC	.4 DC	—	—
V 4 6BA6	-.2 DC ¹	0	0	6.3 AC	82 DC	82 DC	0	—	—
V 5 6AU6/EF94	-.45 DC ¹	0	0	6.3 AC	10 DC	44 DC	0	—	—
V 6 6AU6/EF94	-2 DC ¹	0	0	6.3 AC	42 DC	85 DC	0	—	—
V 7 12AX7/ECC83	215 DC	-1.5 DC ^{**}	17.5 DC	6.3 AC	6.3 AC	125 DC	0	.9 DC	0
V 8 6FG6/EM84	-4 DC	170 DC	0	6.3 AC	0	170 DC	80 DC	170 DC	80 DC
V 9 6V4/EZ80	255 AC	0	285 DC	6.3 AC	0	0	255 AC	0	0

¹ Use a 100,000 Ω resistor in series with the probe when measuring these indicated voltages.

* This voltage will indicate whether or not the local oscillator is functioning and should not vary by more than one volt over the entire tuning range when the oscillator is properly adjusted for the FM band. In measuring this voltage, the common lead of the VTVM must go to the cathode (pin #3).

** This voltage must be measured with respect to pin #3, to which the VTVM common lead is connected.

Quadruple section electrolytic capacitor lugs: #1 285 DC #2 255 DC #3 225 DC #4 220 DC.



SPACE FOR
DYNACO
MULTIPLEX ADAPTER

DYNACO
PC-7

DYNACO
PC-8

DYNACO
300 A 50

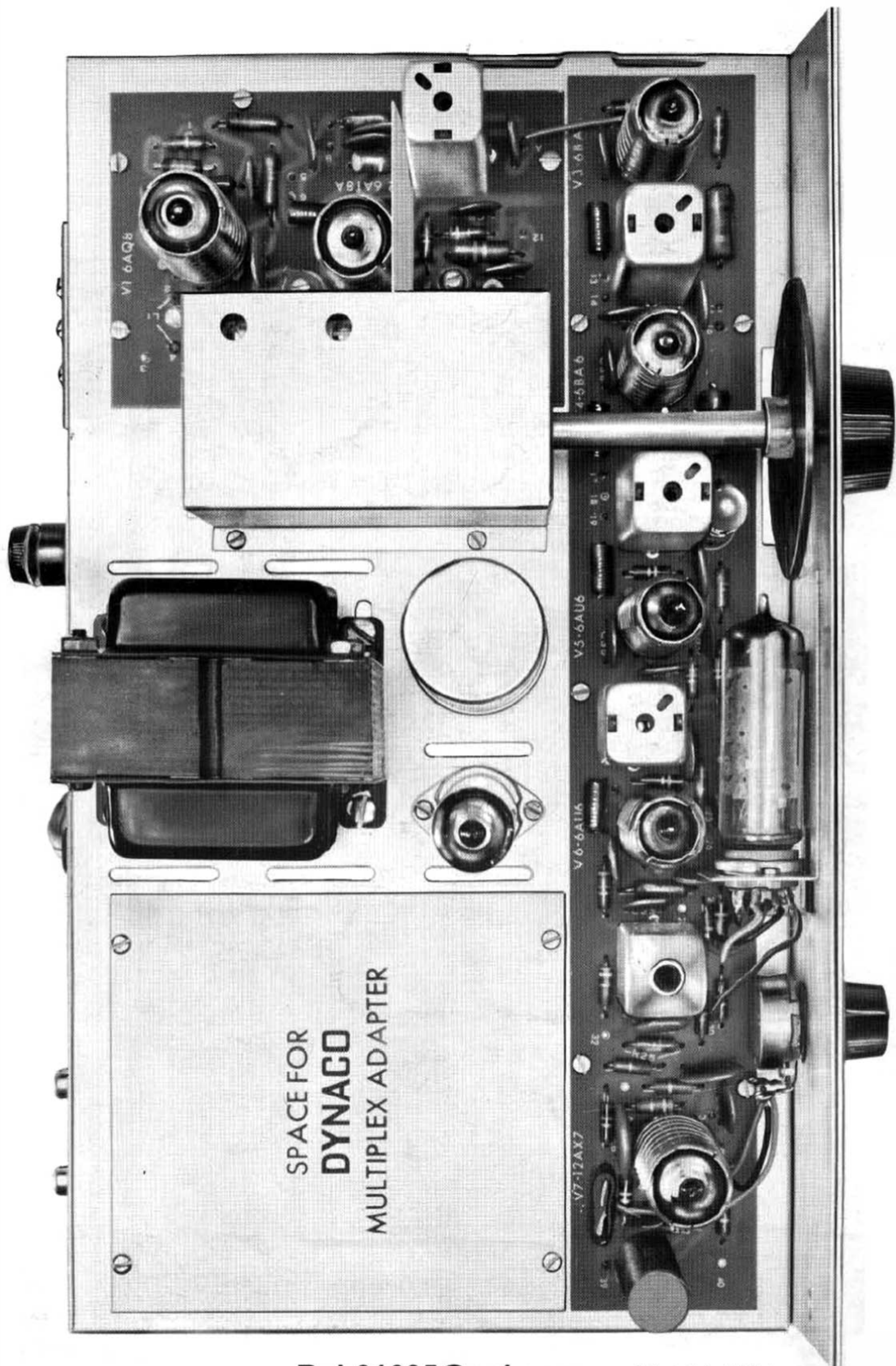

SPACE FOR
DYNACO
MULTIPLEX ADAPTER